

INFO EDUARD

Vol 13, March 2014

ISSUE 45



price US \$ 0.00

GOOD MORNING DA NANG!

PE SETS

Gloster Javelin 1/48
Merlin HC.3 1/48



BUILT

Good Morning Da Nang! 1/48
Bf 109G-6 engine 1/32
T-28B 1/48

BRASSIN

F-4C wheels 1/48
WGr.21 for Bf 109G 1/32

HISTORY

LAST MOMENTS OF GUSTAV
AND HIS GUSTAV

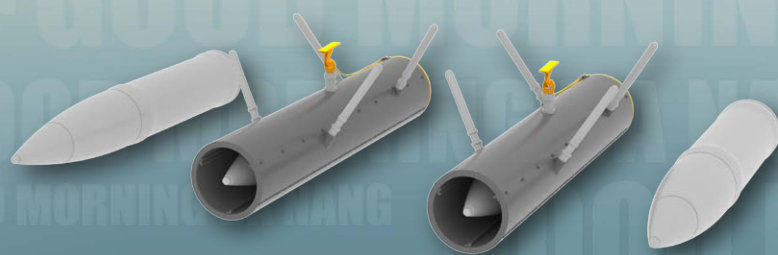

eduard

INFO EDUARD

ISSUE 45

© Eduard - Model Accessories, 2014

FREE FOR DOWNLOAD, FREE FOR DISTRIBUTION!

This material may only be used for personal use. No part of the text or graphic presentations can be used in another publication in any other media form or otherwise distributed without the prior written permission of Eduard - Model Accessorie and authors involved.

Editorial and Graphics - Marketing department, Eduard - Model Accessories, Ltd.

March 2014

CONTENTS

EDITORIAL ■ **4**

BFC ■ **6**

Bunny Racer 1/72

PICTURES ■ **8**

Obrazy z dějin Eduardu v Čechách a v Evropské unii a leckde jinde

KITS ■ **10**

(Good Morning Da Nang 1/48, MiG-15 1/72, Ju 87G 1/144)

BRASSIN ■ **17**

PHOTO-ETCHED SETS ■ **19**

BIG ED ■ **23**

RELEASES ■ **24**

March 2014

HISTORY ■ **25**

Last Moments of Gustav and his Gustav

BUILT ■ **32**

Good Morning Da Nang! 1/48

T-28B 1/48

Bf 109G-6 engine 1/32

EVENTS ■ **40**

Nuremberg 2014

ON APPROACH ■ **43**

April 2014

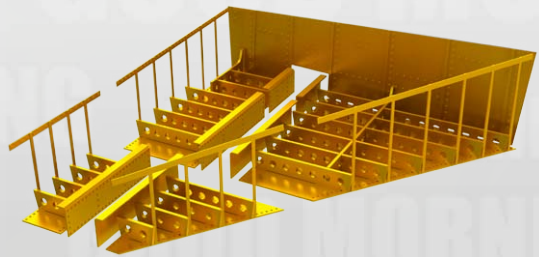

EDITORIAL

March will see the arrival of the Phantom. That is not a secret password from the old Kapitán Kloss series, but an expression of fact regarding the release of our version of the F-4 Phantom II, considered certainly not just by myself, to be a gem in world aviation history, and one of the greatest legends of aviation, period. The Phantom has a relevance to the start of our own company, when in the late eighties during the building of an ESCI Phantom in 1/48 scale, the development of photo-etched brass went through a series of ups and downs, and through this road saw the eventual formation of Eduard. Of course, these were amateurish results at best, but we have since those days been able to produce brass details and modern resin castings for many Phantoms manufactured by world class kit makers and in all three major scales only to return to the Phantom II in all its glory to a standard that we are now able to achieve.

The F-4 Phantom II is a type that I, as well as my colleagues, would dearly love to have in our catalog. We were not able to get to that project on our own terms in time, and were beaten to the punch by Academy, and so we decided to take advantage of our good relationship with that firm and their managers, and asked Mr. Choi if it would be possible to utilize their plastic in our boxes. We were able to come to an agreement despite the fact that Academy themselves have not had this kit in their own catalog very long, only since the first half of last year. We are extremely grateful for the willingness of Academy management to come to an agreement with us on this theme. As you will no doubt be aware, the Academy kit is a very nice one. The designer of the kit is Ivo Braghin, an Italian with Czech roots, who makes his living as a freelance kit designer, among other things that keep him busy, he is feverishly learning Czech and is quite successful at it. Ivo is busy in his field, and even we have something in the works by him, but first and foremost, he works for Revell, for whom he designed, for example, the B-17 and Lancaster in 1/72 scale, or their latest hit, the Bf 109G in 1/32. He also designed for Italeri and, of course, Academy. Our ability to raise the level of detail of a kit is quite well known, as is the level of manufacturing quality, and so we went into the fine tuning of the Phantom with a lot of energy. The ability of our own designers to come up with quality work depends on the original kit for which they are designed, and our team worked very carefully on this kit to do it justice, and for the fact that it will form the basis of other versions that we will progressively release. So, what then can you look forward to? The plastic in our boxings will be in a straight grey throughout, as opposed to



the Academy three color moldings. The plastic will be complemented by masks and both color and non-colored photoetched brass specifically geared to the sizes and engineering of the kit. In terms of accessories, this kit will differ from those before through the inclusion of seatbelts made of fabric, manufactured for us by the firm HGW. Other Limited Edition kits have the inclusion of Brassin resin items. This kit contains no shortage of these items, and includes seats, wheels and exhausts. One of the main points of interests among modelers are the markings options. We have stuck to our usual five options, which we hope will prove to be very attractive and popular. There is no question of their quality, as they are again printed by Cartograf in Italy. The options were entrusted to experts from the nation that originated the product, since we asked ourselves who better to hand this responsibility over to an American, and in this case Geoff Martin, owner of Furball Aero-Design. The more serious of modelers among you will certainly know who this is. The markings can be examined later in this issue and I will add that we will release 3,050 kits. It may seem like quite a bit, but it is, in reality, not. Based on pre-orders it appears that this item will go like the proverbial hot cakes, and not only for the fact this very well equipped kit will sell for a very reasonable 99,95USD/74,95EUR. And this will not be forever, there will be times when you will not be able to get this kit for a lot more than that.

The main new kit is the 1/72 scale MiG-15 in the Profipack line. It follows on the heels of January's MiG-15bis, with which it shares many of its moldings. It does not deviate to any great degree from the predecessor, and the same can be said for the Ju 87G in 1/144 scale in the Super 44 line. The Ju 87G is an older molding but the decals and photo-etched are newer items. The MiG-15, as was the case with the January MiG-15bis release, contains corrected pressings. It will be noticeable by the triple lugs on each of the four sprue frames. In March, we will initiate the replacement of the older, shall we say 'less precise' sprues that

found their way into the initial production run of the 'Czechoslovak Fifteens' kit. We will exchange them one for one, who delivers us the faulty piece will receive a new one by mail, or you can go to your retailer. We will also have a supply on hand of new sprues at the spring shows. Those that exchange their faulty sprues directly through us will also receive a discount coupon for their troubles, applicable towards a purchase at Eduard Store. Exact information will be available on our websites, and will also be published on our Facebook page.

As expected, the installation and integration of our new photoetching line didn't go off without a hitch or some problem somewhere, but the main advantage of being able to etch steel has been realized. Among the March releases, we are offering the first of our new scribing templates, Set No. 00027 Circle and Oval Steel, the first in this new line. Steel sets will be a growing item in our catalog and we do plan on taking advantage of steel in the future. The next two templates are being readied for release in April. Others are also being prepared, and I would expect that this medium will find its greatest use in ship accessories, where its finesse and strength can be used to great advantage.

That is not the only new item for this month. Worthy of attention will certainly be Set No. 49068 Remove Before Flight 1/48 Fabric. These are made out of a new plastic material by HGW, and looks incredibly realistic. I am very pleased with the finished product and I anticipate a great future for this material. Besides the RBF tags, we are also preparing sets of new seatbelts using this material, conceptually different from its predecessors by having fasteners printed directly onto the belt. Thanks to this, its use will be greatly simplified, and the effect is incredible. Keep your eye out for more information on this product, as this has the makings of a small revolution.

Among photo-etched items, there are other things that will attract attention, such as the new Javelin FAW.9 in 1/48 from Airfix and the Merlin HC.3 from the same manufacturer and in the same scale, as well as the Pz.35(t)

in 1/35 and speed brakes for the 1/48 F-4C for the Academy kits. Among other things, March will also see the release of sets covering the Italeri 1/32 scale F-104 and other sets will follow in April. Of note are also three Big Ed sets whose individual component sets are long time best sellers.

Turning our attention to Brassin sets, there is one designed for the 1/32 scale Bf 109G-6 from Revell covering the WGr.21 rocket launchers used towards the end of the war by a list of Luftwaffe aircraft. The moldings are very detailed, to the point that exceeds what you'd expect from a tube with a rocket inside. This set is interesting also from the point of view that it was designed by one of our ladies here, Lenka Antosova. Another young lady is the designer of our American 250lb bomb in the Brassin line and in the same scale, this time by Katerina Sulcova. Women appear to be specialists when it comes to bombs and rockets here, and this month's release of the Mk.82 in 1/48 scale is also the work of Katerina. The ladies are taking over, boys, but at least the F-4 wheels are still a male dominated domain, at least for now!

This month's newsletter also contains a lot of information on the Nuremburg Toy Fair. Much has already been published in various forms, but this month we will present a photo report from our stall and through our eyes. My opinion, wearing my director's hat, is that it was a very positive experience. Our activities over the past year have received praise and our plans much anticipation, and our retail partners are in tune. We have also secured deals that will allow us to expand our Limited Edition line at a good clip. Our redesigned stall was very comfortable, and socially, the activities were feverish. In short...awesome. Often, we have been asked whether or not we received any medals. The answer is that yes, we did... two from ModelFan. One for the Spitfire and all connected to it, and one for...damn, I forgot the name of that car again! No matter, you can find it in the photo report, I'm sure. Do you realize that it has now been twenty years since we received our first medal from ModelFan, in 1994? We were the first ex-communist block country to receive the prestigious award. At that time, this represented quite an adventure for the representatives of Eduard, a description of which can be found here. At that time, as now, this was a great honor. The value of the medal was not only dictated by its size and weight, but also by the process used to determine its recipients. They were handed out in a ceremony that included the participation of significant people in the industry and the publication of winners associated with it was well planned and its word was law. Unfortunately, I have to say that the development along these lines brought with it a certain devaluation of the awards and in my opinion, there are too many awards given out, and some, if not many, awarded products do

not belong among those that are deserving that represent the highest level of the industry. Similarly, other circumstances added to the decline in the value of the Nuremburg model of the year award, but inflation is always a factor behind the devaluation of anything, and in this case, this is evident. It might be better to develop an awards system where the awards are given to a more limited circle of products, preferably in each category, in a given scale, and given to one manufacturer and one product. Something like the Oscars, and the recipients of our Oscars would be determined by a vote of an academy of the modeling industry made up of writers, manufacturers and perhaps retailers. Does that come across as too utopian, or as a possible vision?

One of our guests at Nuremburg was Vladimir Cumak, owner and director of the well known firm Roden. We've known each other for many years and although we are competitors, our relationship is a friendly one. One of the things that we discussed is the purchase of plastic moldings to include in our catalog to commemorate the anniversary of the start of the First World War. Unfortunately, the recent events in the Ukraine have brought the country to the brink of civil war, something that Vladimir had been afraid of a month ago already. We can only stand with and support our friend, and hope that he and his nation step back from the unimaginable and get through the crisis in good health. We wish that all of our Ukrainian friends will get through this crisis and find peace and prosperity instead.

April will see not the Phantom, but the Bunny Racer. It will be the new entry kit into the BFC club in 1/72 scale, which will no doubt make fans of this classic scale happy. More on the Bunny Racer can be found inside this newsle-

tter, but I will add that this is the MiG-15bis packed with photoetching and resin accessories, including new seat belts from the new plastic material described above. We thought 'what the hell...' and even included the female MiG-15 pilot's bra from our advertisement. April will see the initiation of the sprue exchange for the MiG-15, as mentioned earlier. Through the course of March, details on this transaction will be posted on our website and on our Facebook page. The first opportunity to exchange them physically and not by mail will be March 15 at Prosek. And with that, you have been informed that we will be at Prosek, and besides the sprue exchange, there will also be the 'Good Morning Da Nang' F-4 kit available and our Bf 109G-6 in 1/48 will be on display.

Happy Modeling!

Vladimir Sulc.

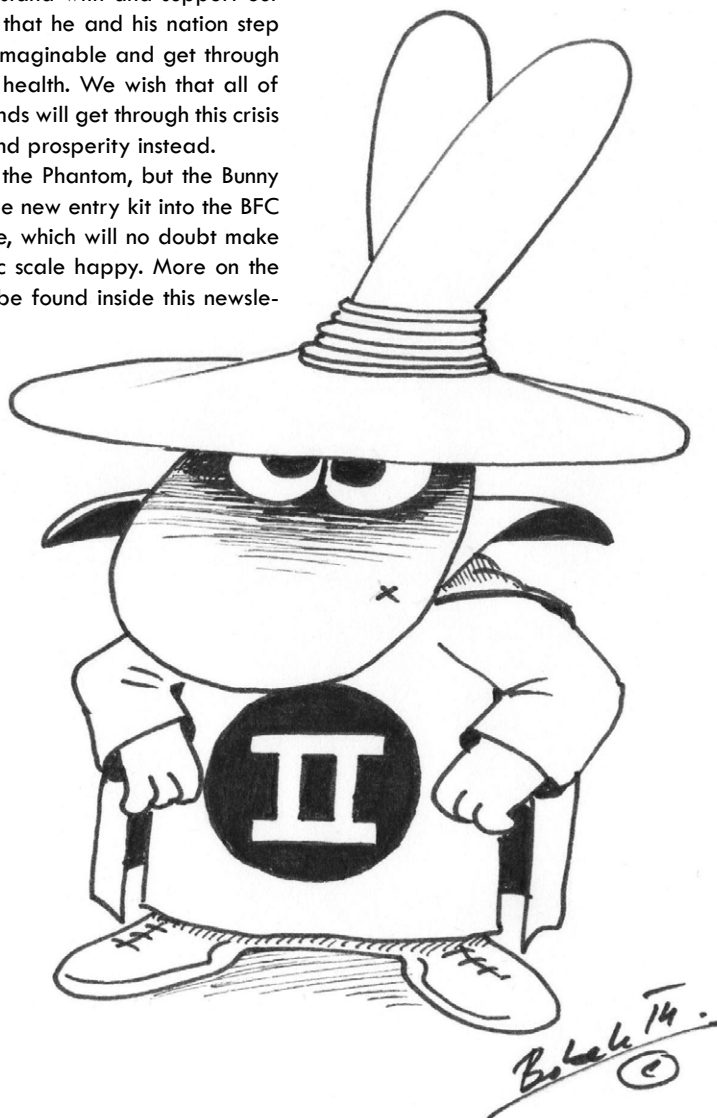



E-Bunny finally brings
a pleasure to the **1/72!**
scale fans!



MiG-15bis

BUNNY RACER

Cat. No. BFC009

CONTENTS:

- Dual Combo - plastic and photo-etched parts for two complete models
- decal sheet for three markings
- Brassin cockpit
- Brassin air brakes
- Brassin wheels (4 pcs)
- photoetched landing flaps
- photo-etched exterior set
- Fabric (polymer) seatbelts
- Polymer bra - aerial combat dummy target for the Soviet female pilot (Korean marking)
- BFC Member Edition T-shirt included

New BFC Activation kit in the
1/72 scale – from **APRIL 2014!**

MiG-15bis, Maj. Eduard Kleinkönig,
White 5, World Air Race Tour,
early 80's

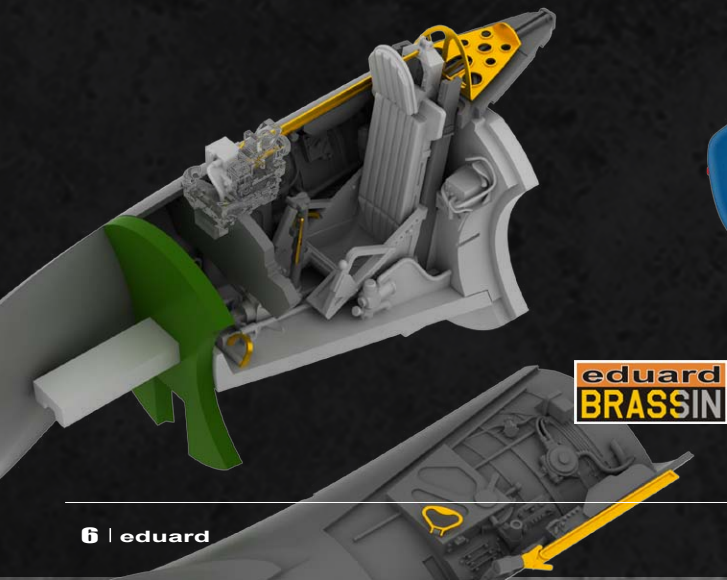
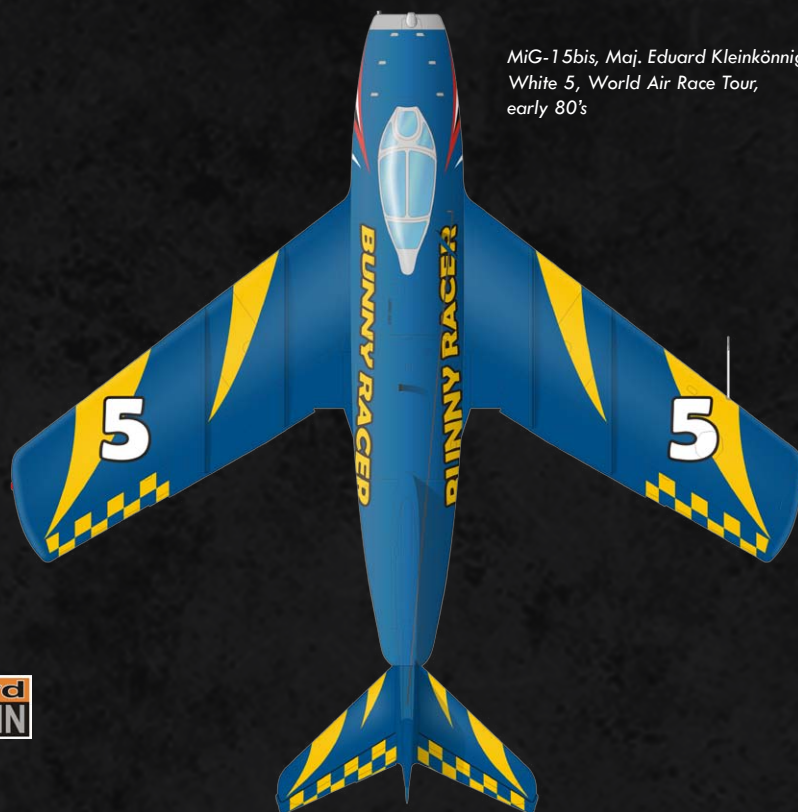

eduard
BRASSIN



eduard
BRASSIN

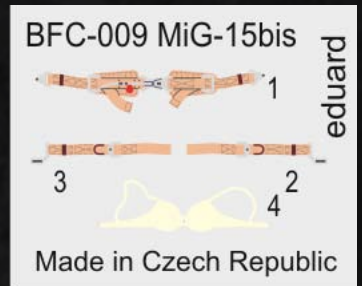
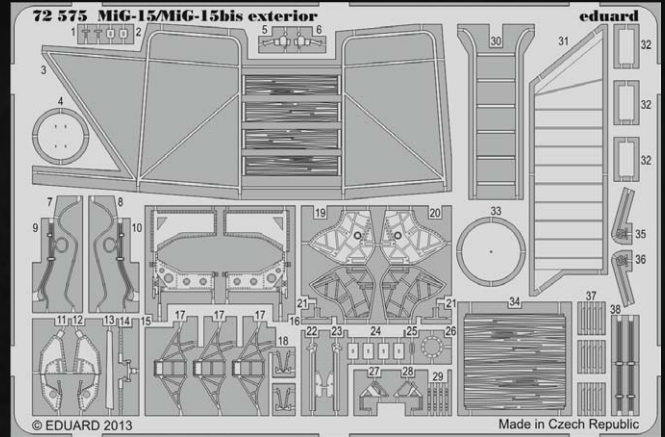
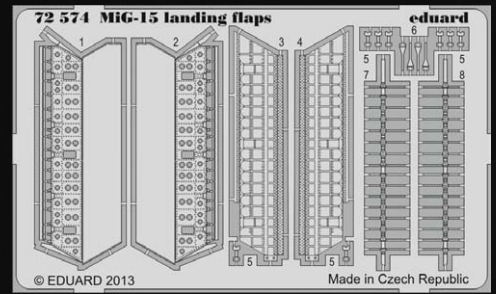

markings:



MiG-15bis, No. 3901, Capt. Jaromir Palecny, 11. slp, Žatec AB, 1960

APRIL 2014!



MiG-15bis, Lt. Nadezda Ivanovna Zayatsovskaya, Soviet instructor, 2nd FTR, Antung AB, Korea, early 50's



(See MiG-15bis promo video on our Youtube channel)



Pictures from the history of Eduard part 1 in the Czech Republic, the European Union and elsewhere

Vladimír Šulc

In my youth, from 1979, I worked at a chemicals plant in Záluží u Mostu. The plant was located in the municipality of Záluží, half way between Most and Litvínov; it was built in the early 1940s as a plant for the manufacture of synthetic petrol. The raw material was brown coal mined in dozens of underground and surface mines situated in the vicinity of the new plant Sudetendeutsche Treibstoffwerke, abbreviated to STW. The factory was inaugurated in early 1943 in the presence of Albert Speer, the Reich Minister of industry. It employed nearly 30,000 people and its monthly production in the first half of 1944 reached 50 000 tons of fuel, petrol and diesel. On May 12, 1944, the factory sustained the first assault from the U.S. 8th Air Force. A total of 140 B-17 aircraft badly hit the plant, dropped 1,650 bombs and caused damage estimated at 48.1 million Reichsmarks. For a long time, this first air-raid was also the most successful; other airstrikes did not meet with such success due to improvements in the defences. After the first bitter experience, air-raid precautions to defend the plant were accelerated; Flakdivision Brűx was dislocated in Most and mass concrete air-raid shelters were built within the plant premises. Tunnel shelters were made in the foothills of the mountains on the outskirts of Litvínov. These buildings have survived to the present day and are even partly used; other remnants of wartime construction activities can also be found in the surroundings. It is also possible to see the buildings of former prison camps: I go walking with my dog around one of the camps for forced labour workers. After a pause caused by the invasion of Normandy, the 8th Air Force struck again on July 21. It bombed quite regularly, with five raids up to October 7. On October 16, this mission was assumed by the 15th USAAF Air Force, operating from Italy, which carried out three raids in October and another three in December. In the last quarter of 1944, the defences of the plant were significantly helped by the weather, whose characteristic feature, lasting as late as into the 1990s, was thick fog; during wartime, it was additionally supplemented by artificial fog which, from today's point of view, was formed by a quite deadly and poisonous slurry. On January 16, the plant experienced a fatal British raid when 231 Lancaster bombers destroyed 70% of the factory, caused damage amounting to 100 million Reichsmarks and killed 105 people. After this raid, fuel production failed to recover, perhaps also because of the other three raids, including one American attack when STW became a substi-

tute target within the air raid on Dresden on February 14. The very next day, the plant was hit by another night RAF raid; the RAF then returned on March 5, after which STW was removed from the list of targets.

After the war, STW in Zaluží went to the Soviet Union as war booty; but already in June 1946, the Soviet Union waved its property

nérská; moreover, it does not make any difference, it does not mean much to our story. People just call the plant Staliňák or the chemicals plant, in Czech khemichca.

In this ChZ ČSSP, I worked in the newly built part of the factory called Petrochemie (Petrochemistry) in the production of polypropylene. I developed my career as a chemist and



Target photo of the Brűx (Most) area taken on the 12 September 1944 mission. The white smoke path came from the smoke bomb dropped by the leading plane.

rights and handed the plant over to the Czechoslovak state. In January, it was renamed Chemické závody J. V. Stalina (Chemical Plant of J. V. Stalin) and since then, therefore, the chemicals plant in Litvínov has been called "Staliňák". In the second half of the 1950s, communists found (to their surprise) and admitted (after much hesitation) that Stalin was not the good uncle Joe, liberator, philanthropist, brilliant military leader, economist, father of nations and even the discoverer of democracy, but rather a dictator and mass murderer contemptuous of human life and even a ruffian worthy of damnation and oblivion; the factory was then renamed Chemické závody Československo-sovětského přátelství (Chemical Plants of Czechoslovak-Soviet Friendship), abbreviated to ChZ ČSSP as this mad name could hardly be remembered let alone pronounced. I do not know the actual name of this factory. I think there are several companies operating on its premises, such as Česká raf-

gradually became quite a well-known figure thanks to my participation in several scrapes of a medium-weight category and because I worked on shift A, led by Julius Dany, foreman, one of the legendary figures of Staliňák and an eminent personality who has left an indelible mark on my personal development. In the summer time, this swarthy man of Hungarian origin moved around the chemicals plant in slippers. During winter, he wore a green-as-grass knitted cap with a red star stitched on that he called "Bud'onovka" because his wife had made it, her first knitting attempt, at a time when a Soviet series "How the steel was tempered" was shown on TV; he was also the inspiration for the name of our company. The name "EDUARD" was my nickname on that time, and it was created due to Julius Dany's passion for reading. He regularly told us, his workers and working intelligentsia, about his reading experiences. When he was reading Poláček's book "There were five of us",

his tales were particularly colourful. One day, during a period fraught with the consequences of one of my beginner mistakes in handling our complex polymerization operation (I think that I accidentally discharged a silo with produced polymer) resulting in a failure to meet the state plan for the month of March (due to which I was quite hated both by operation management and normal workers, who due to me did not get a bonus), Julius Dany told us about the main characters of the book, especially about Eda Kemling. Looking at me, foreman Dany said: "Gentlemen, this Eda Kemling is as stupid as this Šulc!" So I got it. From that moment on, everybody called me Eduard, and this nickname spread like wildfire even though I fought against it like a lion, cursed, scuffled and ostentatiously did not respond. Nothing doing, I have remained Eduard ever since. It got so bad that many no longer knew me by my real name. My career at ChZ ČSSP ended on February 11, 1985 at 5:00 p.m. when I suffered severe burns to 60% of my body in a small industrial accident and entered the legends and history of Staliňák. The consequences of my injuries, which required several years of treatment, did not allow me to continue working in the chemicals industry. However, it did not divert me from chemistry that much despite the opinions of assessment committees. After my release from hospital, I quickly shrugged it off; suddenly, I had a lot of free time that I devoted to my hobbies which, as it happens, soon became one of my sources of additional revenue. This mainly concerned photography and modelling, which I creatively linked as I had discovered the existence of photo-etchings. I really liked them but I thought they were expensive. Like a good Czech in the era of high Husák communism, I began to brood over their self-help production. One of my co-workers from the chemicals plant, Ctirad Kuřák, with whom I often worked in photography (e.g. at his wedding or during car races), gave himself non-professionally to the home production of printed circuit boards. As you know, everyone was a handyman in the former Czechoslovakia. Someone distilled schnapps, someone made jams, and someone else produced photos or bred rabbits. Ctirad repaired appliances and made printed circuit boards. For their production, he had a grandiose device composed of a centrifuge standing in an oil barrel that applied a photosensitive emulsion to the cuprextite surface, a sun lamp as the UV radiation source and a set of photographic plates to develop the exposed plates and for subsequent etching in a ferric chloride solution. He kept all these things inside the factory behind the wall of the polypropylene production control room, in an area where electrical devices and drivers were installed, which created a functional diagram of the entire operation on the other side of this wall. Occasional runs of the centrifuge used to have fatal consequences as this infernal machine caused a drop in line voltage, resulting in failures of some circuits associated with emergency alarms. Therefore, my reflections on the home production of pho-



Bombs dropped from a B-17G of the 384th BG heading on their target – STW Brůx. 12th September 1944.

to-etchings were directed to Ctirad, his equipment and extensive knowledge. I thus found him and acquainted him with my intentions, which immediately got his enthusiasm going. This was Ctirad's personality trait; he was very creative and liked to try out new things. So we set out to develop photo-etchings, having no idea what we were tampering with (as it used to be). In the first stage, however, it was necessary for me to visit the chemicals plant from which I had recently been officially dismissed and removed from the list of employees. Therefore, I had to forge an employee permit authorizing me to enter the plant. Due to some affection, I did not fit the fake with my photo but a picture of Vladimír Remek, the astronaut, in a spacesuit, that Mr. Remek, Hero of the Soviet Union, who had recently become the Czech ambassador to Russia. To avoid any misinterpretation, I would like to say at this point that I consider Mr. Remek a decent man in whom our country should take pride, and that I also believe that his appointment as ambassador was not a bad move though Mr. Schwarzenberg, whom I voted for in the famous presidential election, has a different opinion. At the same time, I would also like to warn the authorities dealing with criminal proceedings that the above-mentioned forgery of a public document was committed back in 1987 and should therefore be time-barred even though it was apparently committed in criminal conspiracy with the appointed Ctirad Kuřák. I went to the chemicals plant, Petrochemie, properly and regularly over the next two years, through the gate waving the card with its portrait of the astronaut, always when Ctirad had night shifts, which was often the case as he liked changing shifts with his colleagues for this purpose. I intend to conceal the real reasons; while constructing a legend, I will affirm that it was because I wanted to develop photo-etchings. After nearly two years of

intensive and thorny development conducted in the OKM workshop of ChZ ČSSP Petrochemie in Záluží u Mostu, we attained the first useable results, which I proudly incorporated into my model of the Phantom, version F-4E. Then, however, events gained such speed that they flushed away all the past together with my Phantom.

In spring 1989, we considered our results to be so good that we started thinking about using our expertise in serial production. At that time, the socialist Czechoslovakia was going through a communist imitation of the social and economic reform called "Přestavba" (Reconstruction), which allowed legal business enterprising under certain very restrictive conditions. After a short hesitation (when we tried to sell our idea to Cooperative SMĚR), we decided to organize our own company. Ctirad Kuřák obtained a business license and we co-opted a new partner, Slávek Motl, who offered his economic knowledge and helped us acquire production facilities for the newly organized company in the basement of the apartment building where Ctirad and his family lived. After a few weeks, our team was supplemented by Miloš Žihla, a photographer, with whom we (Ctirad and I) had worked in the chemicals plant. Karel Pádár, the most famous Czech modeller at that time, with extensive experience in photo-etchings as well as international trade in plastic models, joined us soon afterwards. There were five of us and the great adventure began.



29th GIAP, Dachang Air Base, Shanghai, China, spring - summer 1950

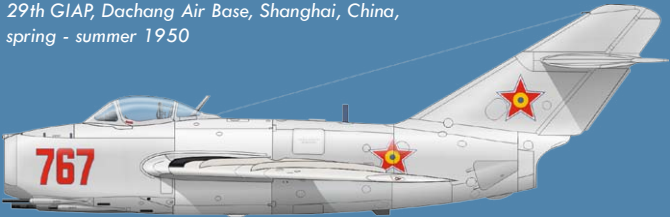

c/n 231767, Romanian Air Force, Deveselu Air Base, 1962



c/n 120077, flown by Major Alexei A. Mikoyan, the Deputy CO of 274th IAP, Kubinka Air Base, early 50ties



c/n 108023, 176th IAP, Antung Air Base, Korea, April 1951



Polish Air Force, 1st PLM, Warsaw - Babice Air Base, 1951



MiG-15

ProfiPACK edition

1/72, Cat. No. 7057

- 5 markings
- photo-etched sets
- painting mask
- Cartograf decals

RECOMMENDED:

672021 MiG-15 airbrakes (Brassin)

672022 MiG-15 cockpit (Brassin)

672008 MiG-15 seat (Brassin)

672007 MiG-15 wheels (Brassin)

72575 MiG-15/ MiG-15bis exterior (PE-SET)

72574 MiG-15 landing flaps (PE-SET)

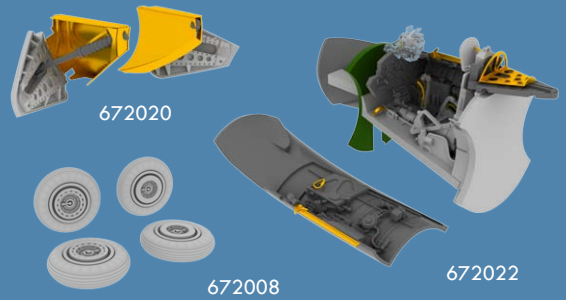

BUY MiG-15 1/72



SUPER44

Dual Combo!

Ju 87G

1/144, Cat. No. 4430



German WWII dive bomber

- 3 markings,
- decals and photo-etched set,
- Dual Combo – two sets of plastic parts in one box.

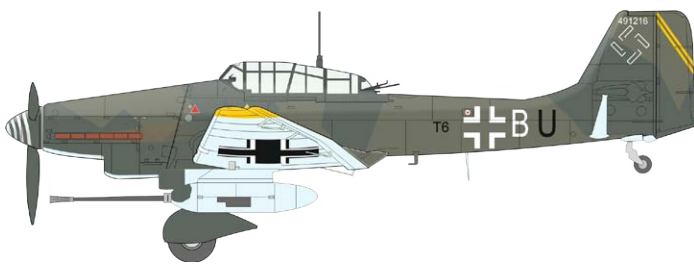

Ju 87 G-2 with SG 2 on the Eastern front 1944-45

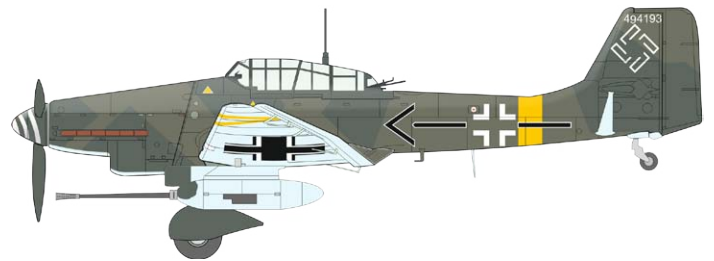

Ju 87 G-2 flown by Oberstleutnant Hans Ulrich Rudel with SG 2 on the Eastern front 1944-45

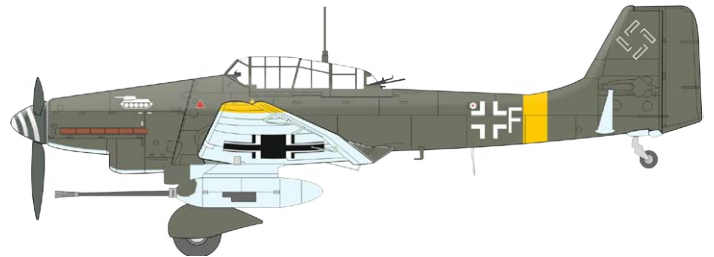

Ju 87 G-2 /Versuchskommando für Panzerbekämpfung/1943

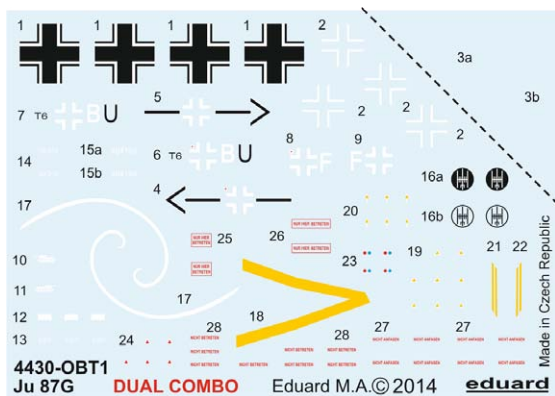

BUY Ju 87G 1/144 



GOOD MORNING DA NANG!

1/48, Cat. No. 1186

- plastic parts F-4B, Academy,
- 5 attractive markings,
- Cartograf decals - 2 large sheets,
- color photo-etched sets and painting mask,
- Brassin: seats, exhaust nozzles, wheels,
- FABRIC seatbelts.

BUY Good morning Da Nang 1/48

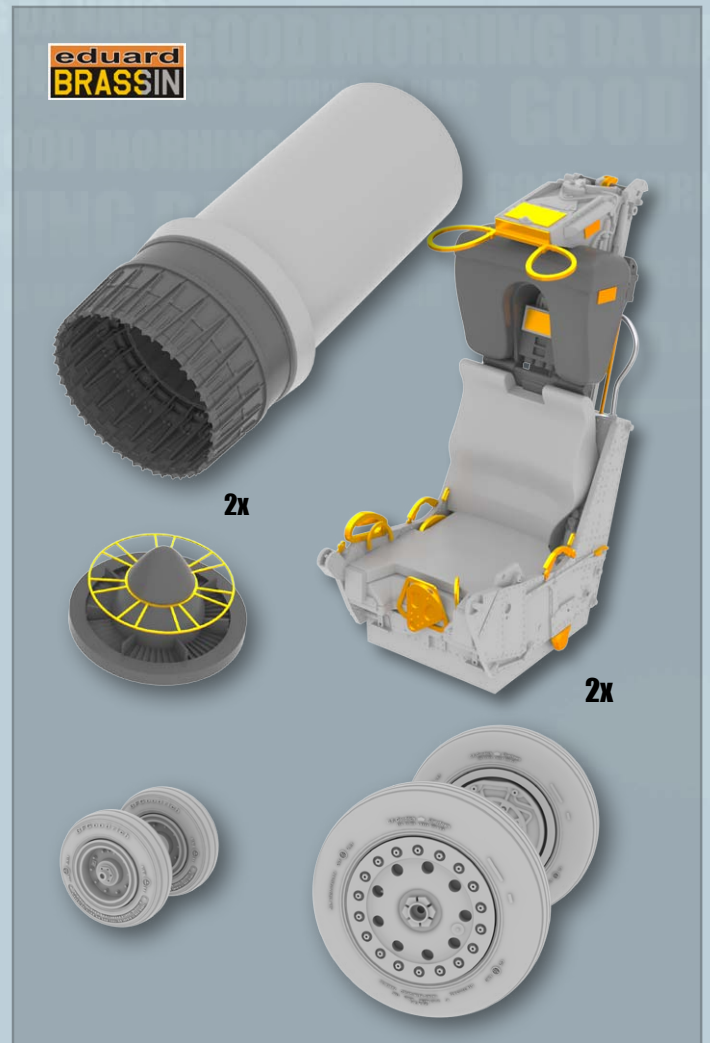

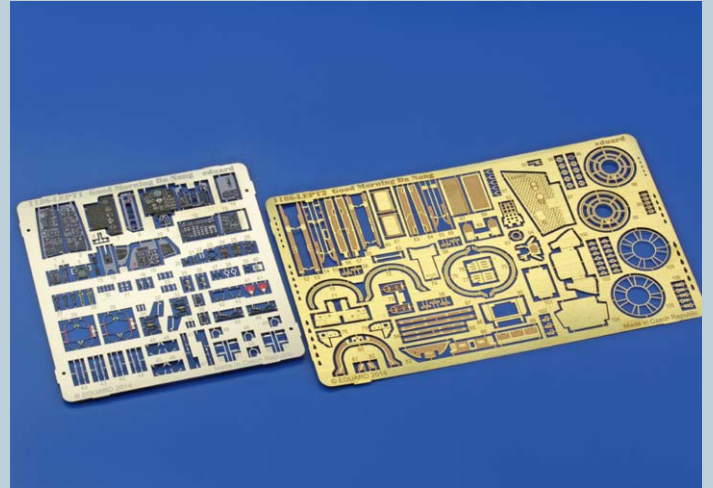
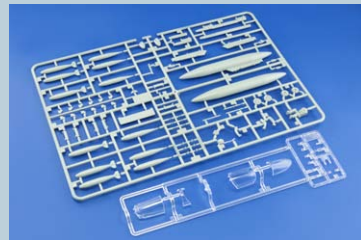
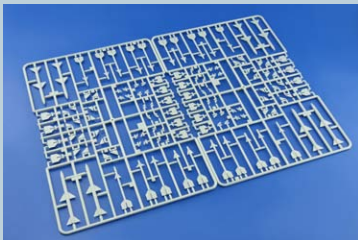
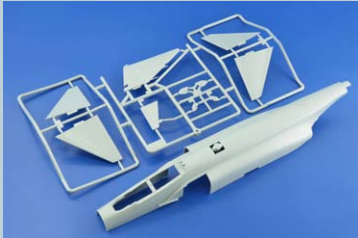
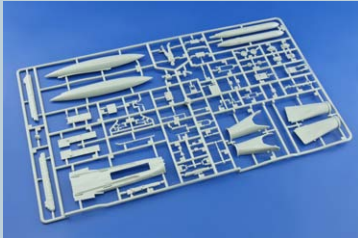
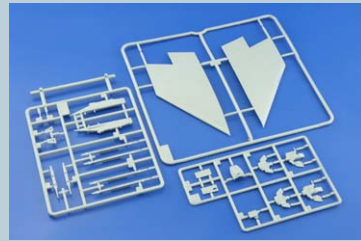
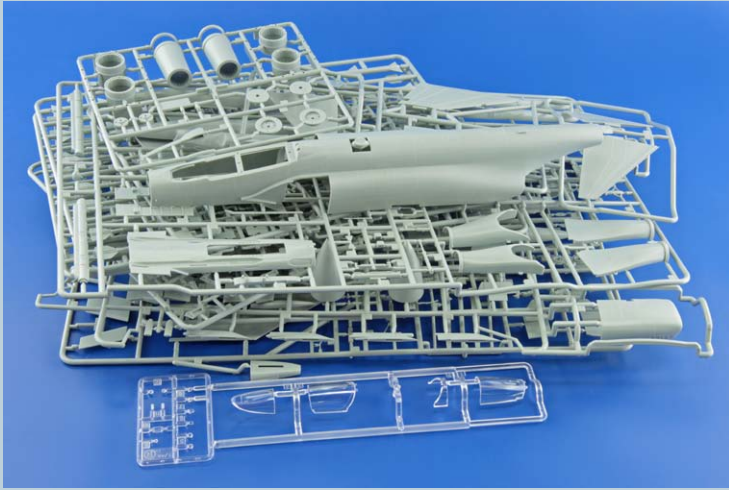

DECALS AND COLOR PROFILES DESIGNED BY:

Geoff Martin



F-4B 153020, VF-161 "Chargers", USS Midway, May 1972

Lt Cdr Ronald McKeown and Lt John Enscher were flying the squadron's CAG jet when they shot down two MiG-17s on May 23, 1972. Three months later on August 25, 1972 Lt Enscher was again the Radar Intercept Officer assigned to „NF-100“ when the aircraft was struck by a SAM over Nam Dinh. The pilot, Lt Cdr Michael Doyle was killed. Lt Enscher survived and was taken prisoner and held for the duration of the war.



USS MIDWAY



F-4B 153019, VF-111 "Sundowners", USS Coral Sea, March 1972

Lt Garry Weigand and Lt (JG) William Freckleton shot down a MiG-17 while piloting „NL 201“ on March 6, 1972. A black MiG-17 silhouette was applied to both the left and right splitter plates to record the event. Assigned Straight from the factory to VF-213 in 1966, 153019 was flown by Lt David McCrea and Ens David Nichols on the night of December 20, 1966 when they would intercept and destroy an AN-2. They yellow star on the left and right splitter plates signifies this kill.

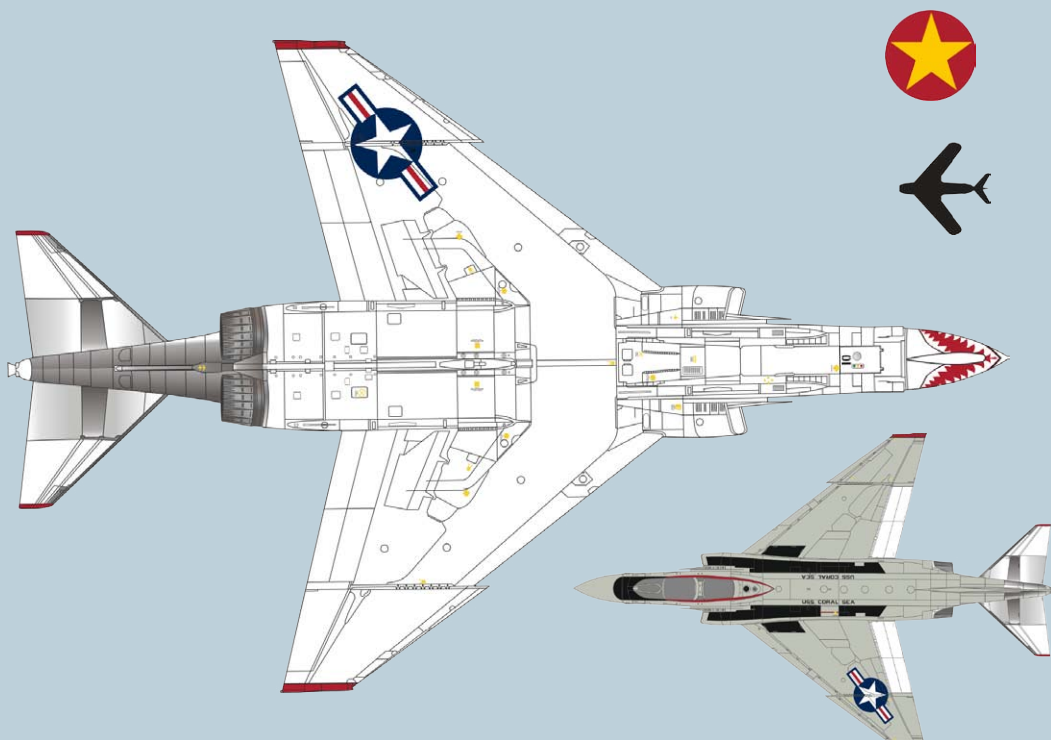

DECALS AND COLOR PROFILES DESIGNED BY:

Geoff Martin

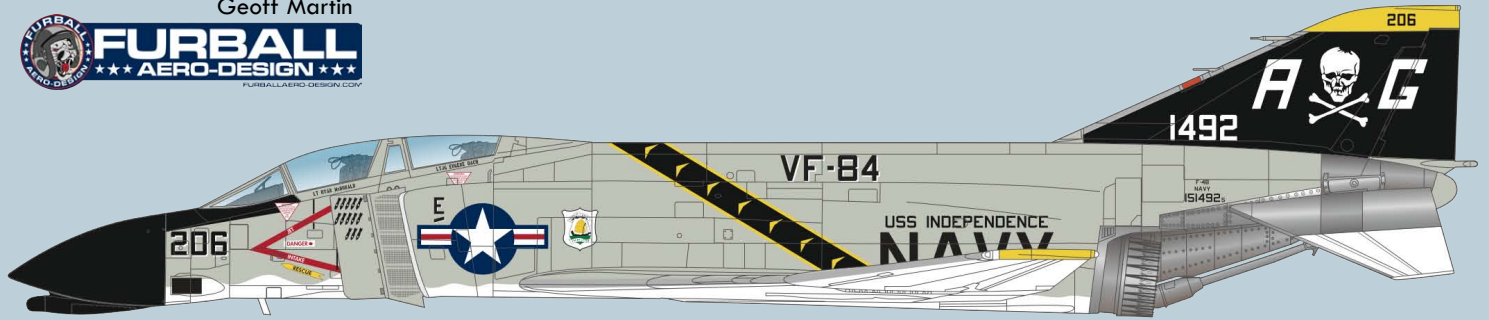

F-4B 151492, VF-84 "Jolly Rogers", USS Independence, 1965

VF-84 was deployed for seven months as part of Carrier Air Wings 7's contribution to the Rolling Thunder bombing campaign. During this time VF-84 would log 1507 combat sorties, while operating from Yankee Station in the Gulf of Tonkin. For their outstanding performance in combat, the Jolly Rogers earned the Navy's coveted „Battle E“ award. It is during this time that the „Tonkin Gulf Yacht Club“ badge became popular with many CVW-7 squadrons.



F-4B 152238, VMFA-542 "Bengals", Da Nang Air Base, South Vietnam, 1966

"WH-1" served as the personal mount of the Bengals' three squadron commanders AKA, „Tiger Leads" during the squadron's 2 deployments to Da Nang Air Base between 1965 and 1966. Flown on over 100 missions, 152238 would eventually be transferred to VMFA-323 and lost to AAA fire in 1967. This forward deployed combat weary aircraft was heavily weathered, with numerous corrosion control touch-ups and hydraulic fluid stains present.



F-4B 152258, VMFA-323 "Death Rattlers", Chu Lai Air Base, South Vietnam, 1967

The Death Rattlers were one of many front line forward deployed Marine Fighter/Attack squadrons to see service in the Vietnam conflict. Specializing in the close air support (CAS) mission, The Death Rattlers provided direct fire for the Marines on the ground. They would go on to complete 3 tours between 1966 and 1969, losing eleven Phantoms during that period. „WS-11" racked up an impressive mission tally and was a combat workhorse that would survive the war and eventually be converted to a QF-4N. The aircraft was moderately weathered with some corrosion control touch ups.



eduard fashion

LIMITED EDITION

FULLCOLOR ARTWORK COTTON T-SHIRT (BY REZAVA VRTULE)

(SIZE: M, L, XL, XXL, XXXL)

BUY



NOT SOLD SEPARATELY!



With kit Cat. No. 1186
Good Morning Da Nang!

sizes:

M (1186X-M)

L (1186X-L)

XL (1186X-XL)

XXL (1186X-XXL)

XXXL (1186X-3XL)

**GOOD
MORNING
DA NANG!**

ON EDUARD STORE ONLY!

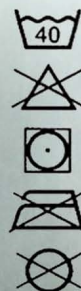



2 pieces of German WWII air-to-air unguided rockets. Photo-etched details included.

BUY WGr.21 for Bf 109G 1/32 

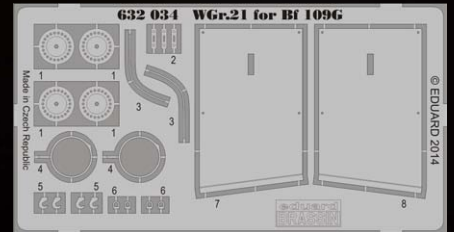
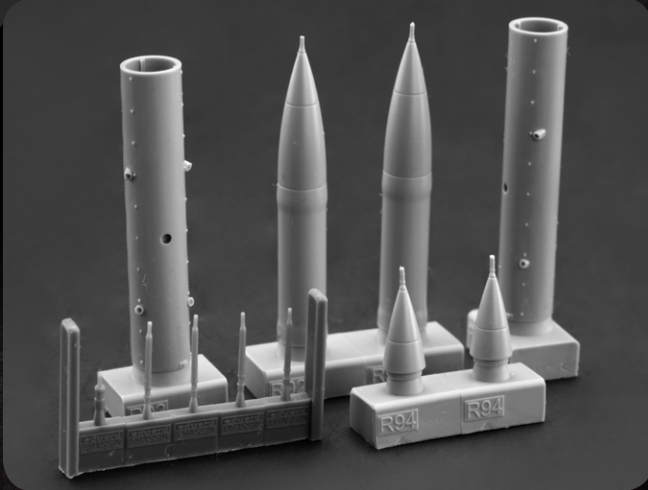

632036
US 250 lb bombs
1/32

2 pieces of US WWII bombs.
Photo-etched details and decals included.

BUY US 250 lb bombs 1/32 

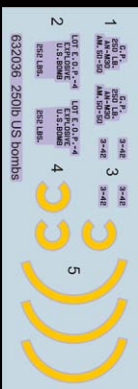
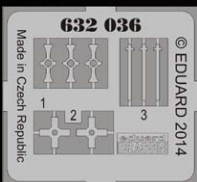
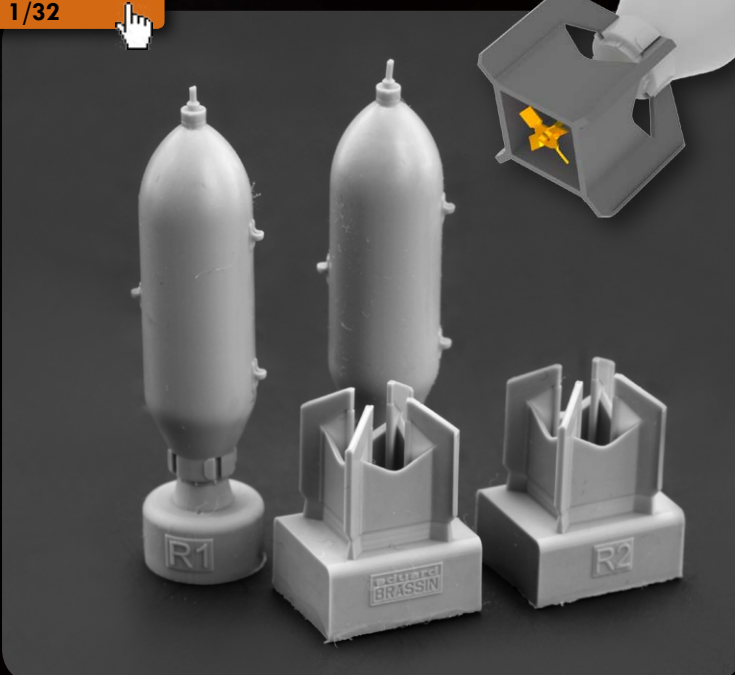
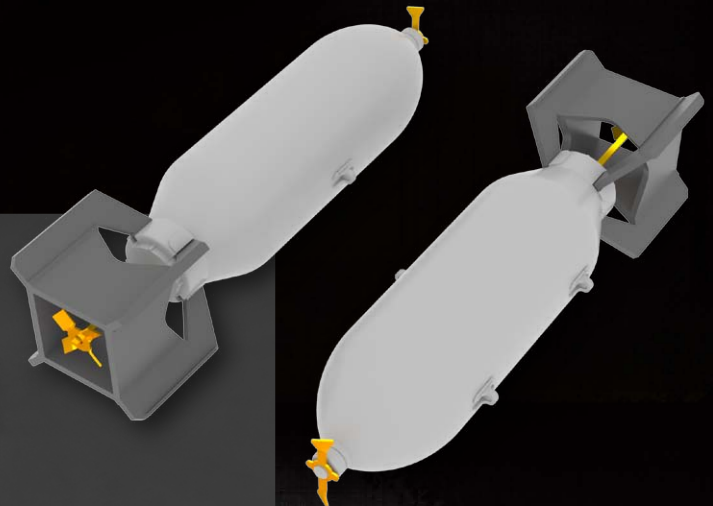

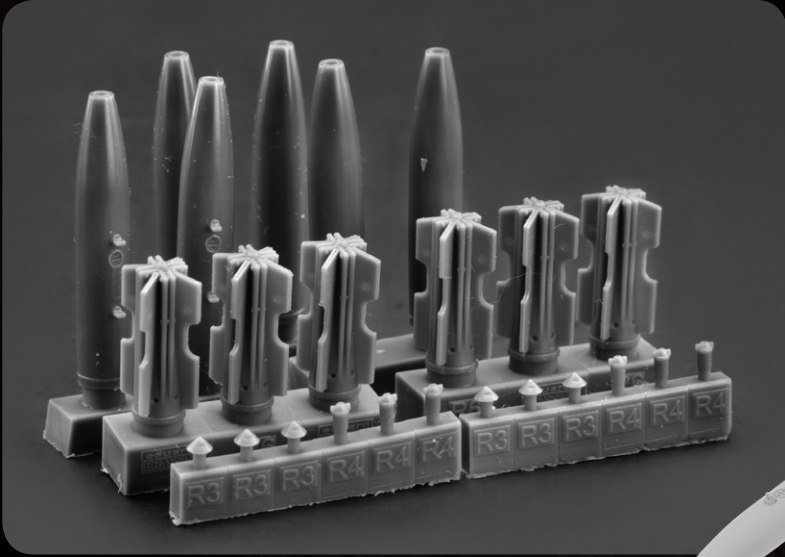

648137
Mk.82 bomb w/ airbrake late
 1/48

6 pieces of US unguided, low-drag general-purpose bombs. Decals included.

BUY Mk.82 bomb w/ airbrake late 1/48



648142
F-4C wheels
 1/48 Academy

Brassin set of wheels for F-4C consists of 2 main landing gear wheel, 2 front wheels and slip blocks (6 pieces).

BUY F-4C wheels 1/48



PHOTO-ETCHED SETS

SELECTED

Pz.Kpfw.35(t)
1/35 Academy (36267)

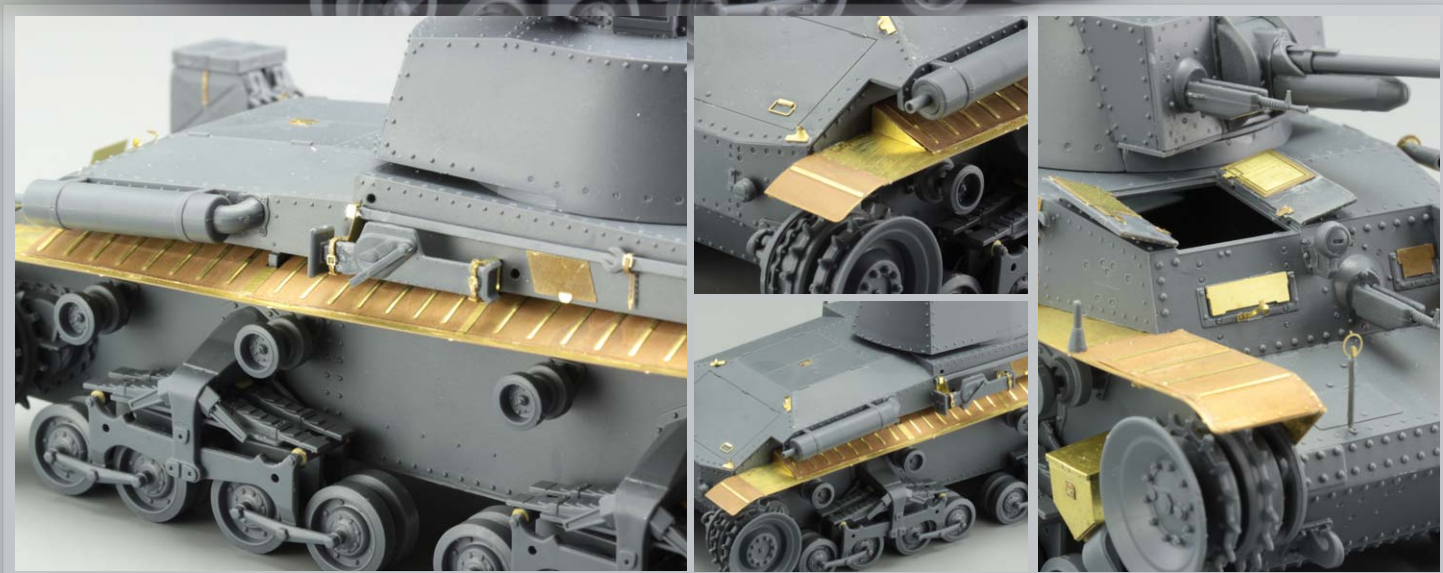

Gloster Javelin FAW.9/9R air brakes 1/48 Airfix (48742)

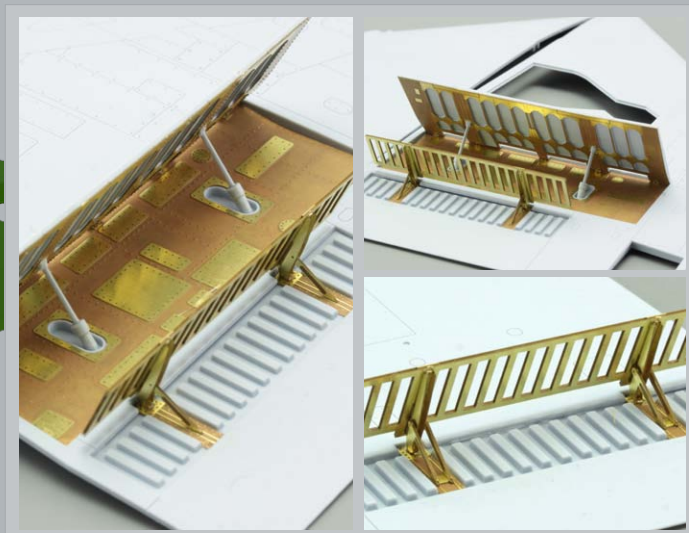
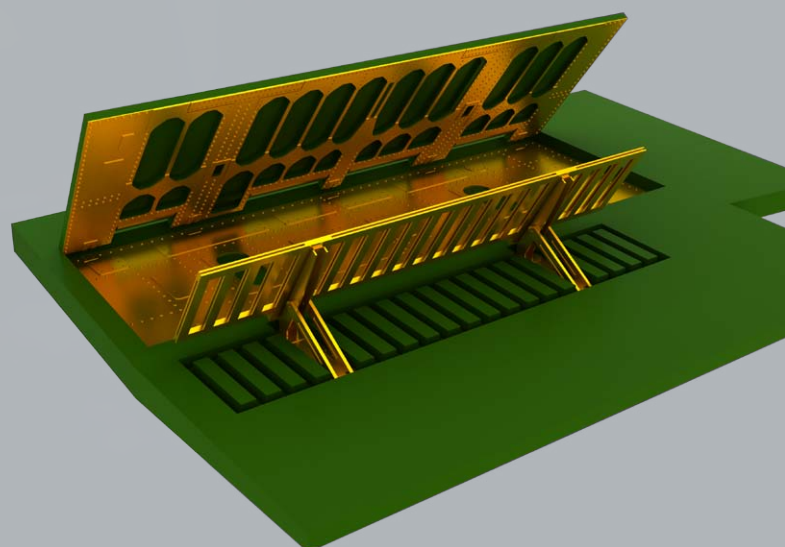

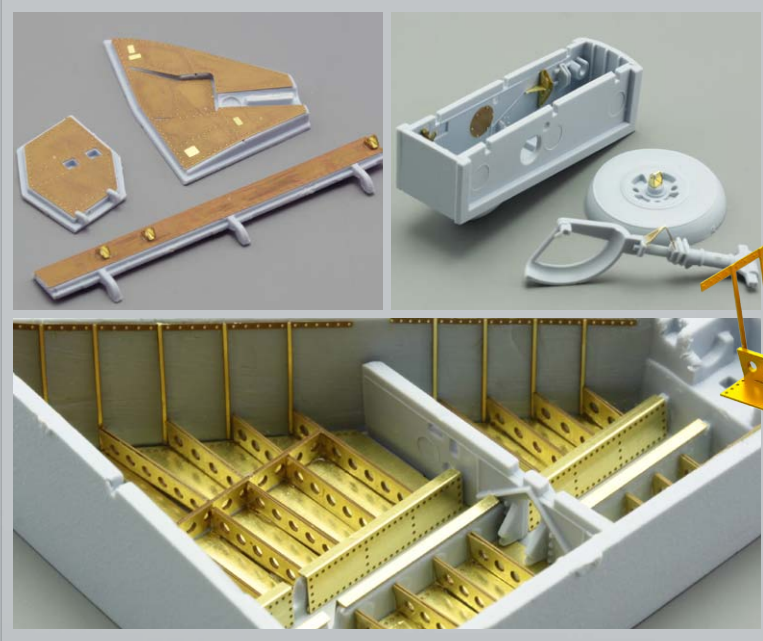

Gloster Javelin FAW.9/9R undercarriage
1/48 Airfix (48796)

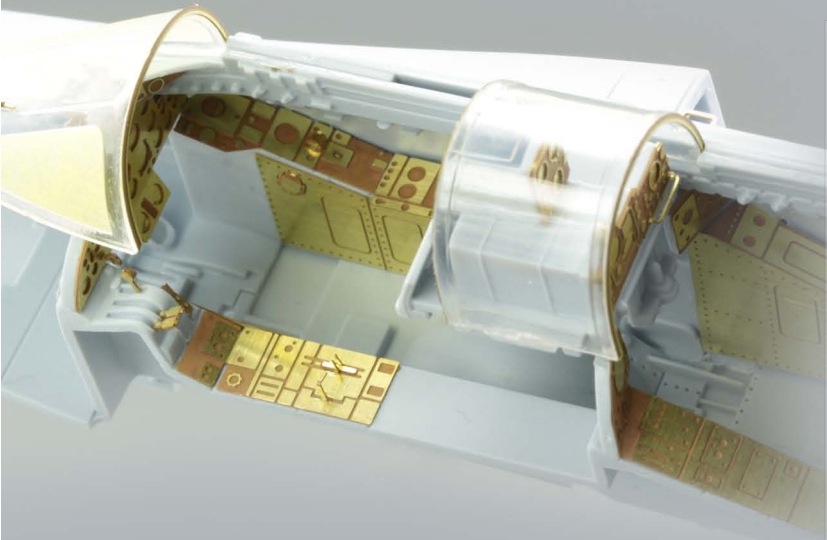
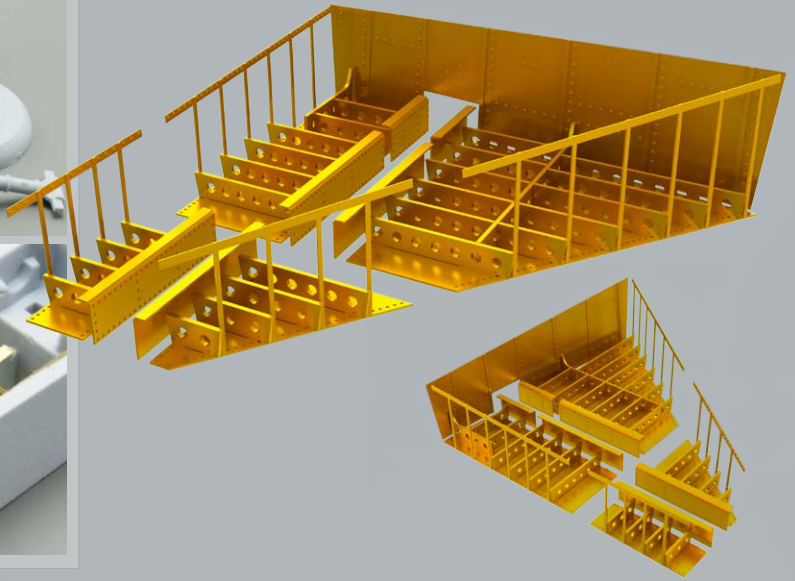

Gloster Javelin FAW.9/9R S.A. 1/48 Airfix (49667)

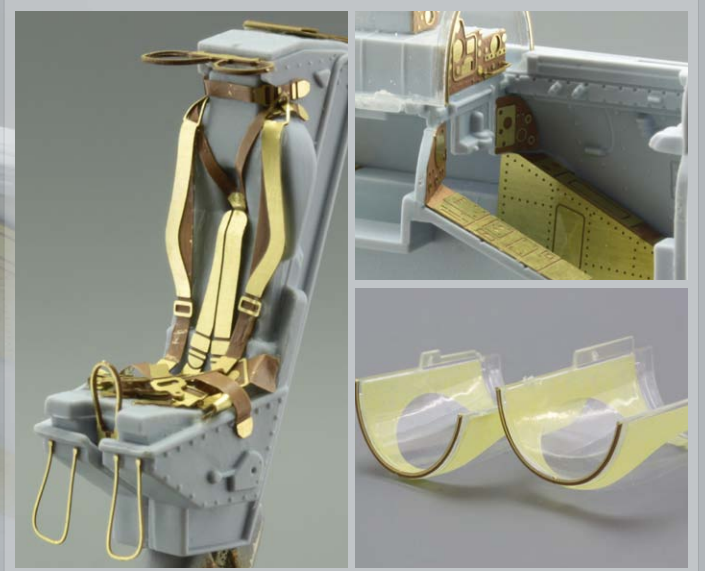

F-35B exterior 1/48 Kitty Hawk (48792)



Merlin HC.3 exterior 1/48 Airfix (48803)



Merlin HC.3 interior S.A. 1/48 Airfix (49647)



F-4C air brakes 1/48 Academy (48802)

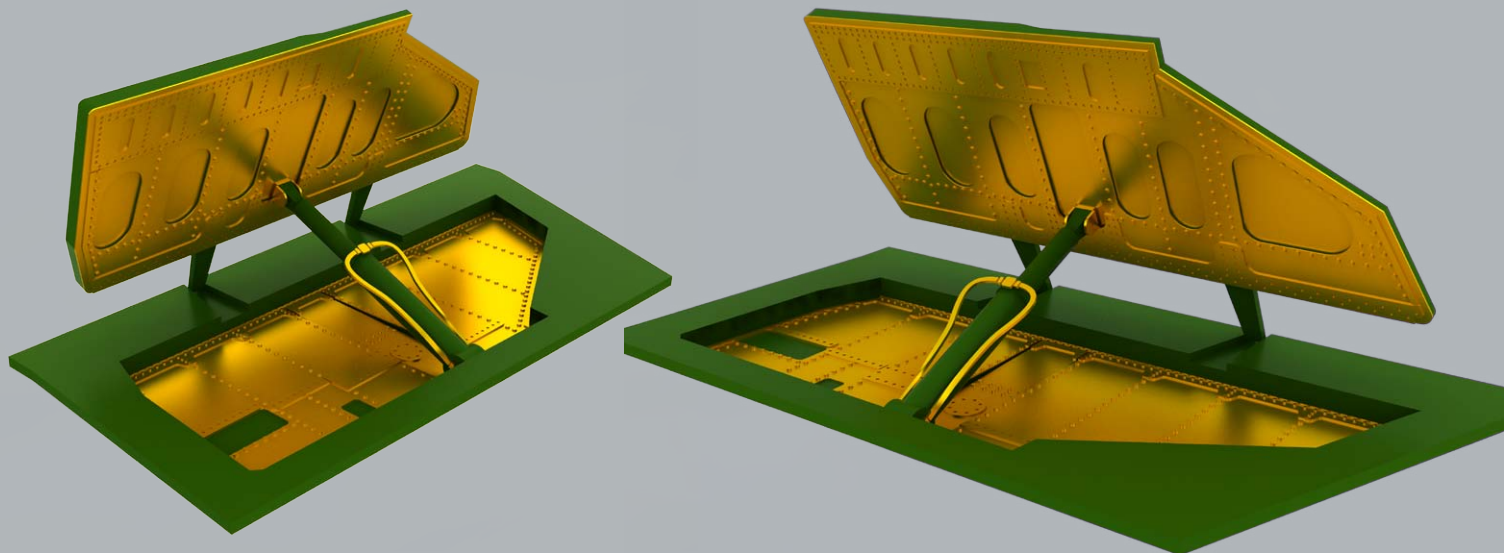

PE-SETS

Me 410A-1 S.A. 1/48 Meng (49668)

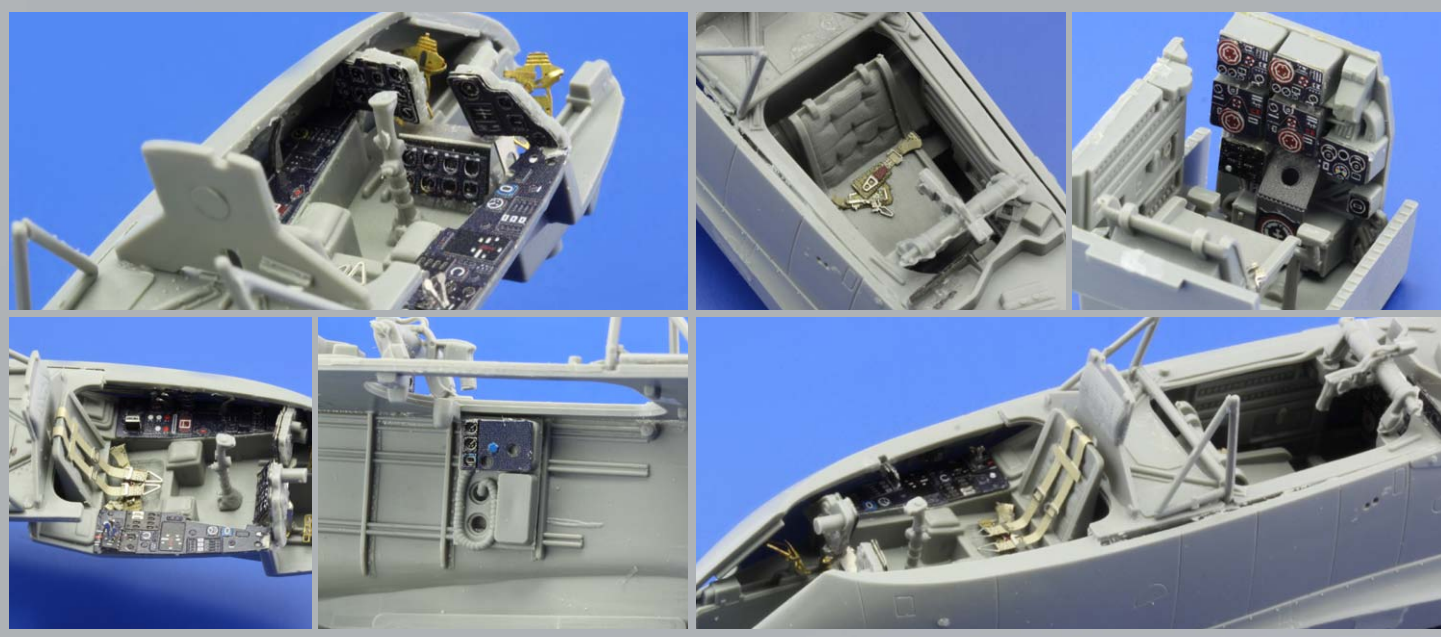

Circle & oval STEEL (00027)

JUST STEEL...!

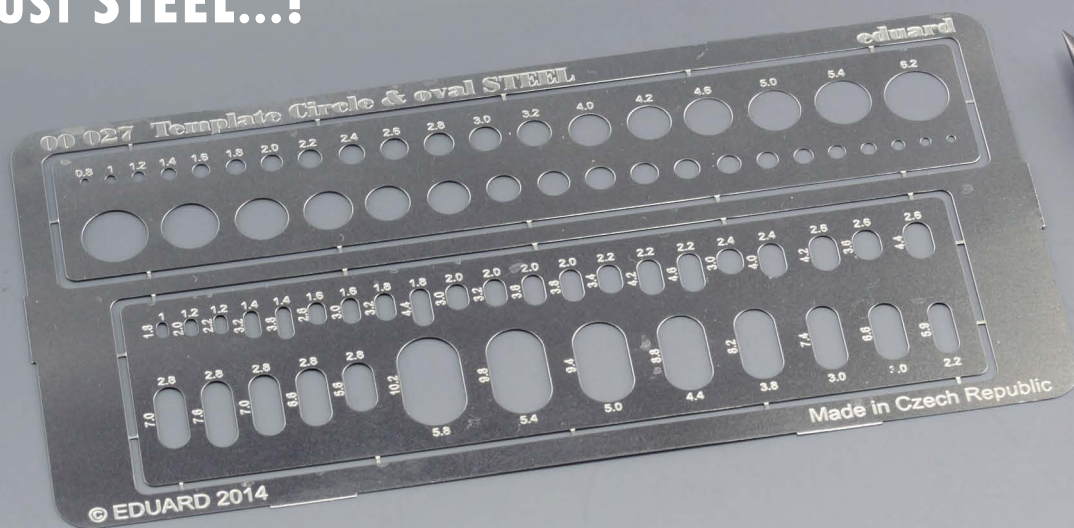

HOT NEW



not part of the product

EDUARD PRESENTS: FABRIC PERIOD

Remove before flight FABRIC 1/48 (49068)

Realistic and easy to assemble combination of colored fabric, rubber and photo-etched parts.



HOT NEW

All sets included in this BIG ED are available separately, but with every BIG ED set you save up to 30%.

BIG ED

BIG3336 B-25J STRAFER 1/32 HKM

32746 B-25J seatbelt

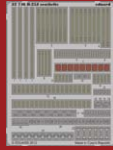

32319 B-25J exterior

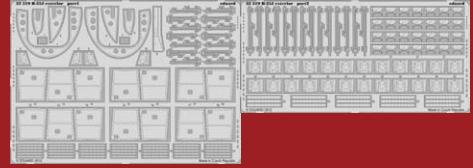

32321 B-25 bomb bay

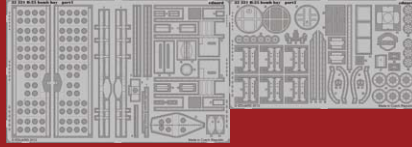

32756 B-25 fuselage interior

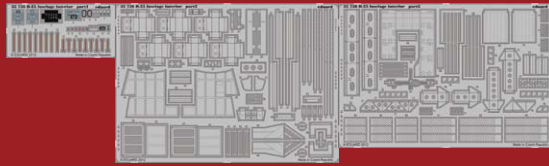

32801 B-25J nose guns and ammo belts



JX159 B-25J gun nose

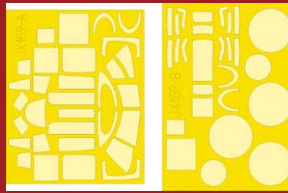

32787 B-25J gun nose interior S.A.



BIG3337 Ju 88A-4 1/32 REV

32352 Ju 88A-4 exterior



32632 Ju 88A seatbelts



JX160 Ju 88A-4

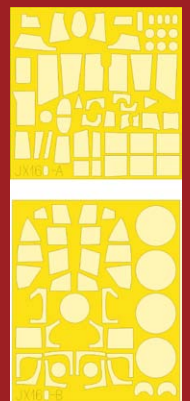

32800 Ju 88A-4 interior S.A.



32 613 Ju 88A-4 glider



BIG4997 SPITFIRE Mk.IXc 1/48 EDUARD

49639 Spitfire Mk.IXc



48765 Spitfire Mk.IXc landing flaps

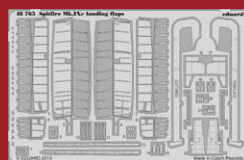

48766 Spitfire Mk.IXc surface panel

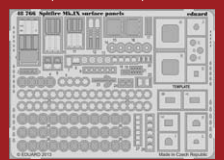

32801 B-25J nose guns and ammo belts (BIG3336)

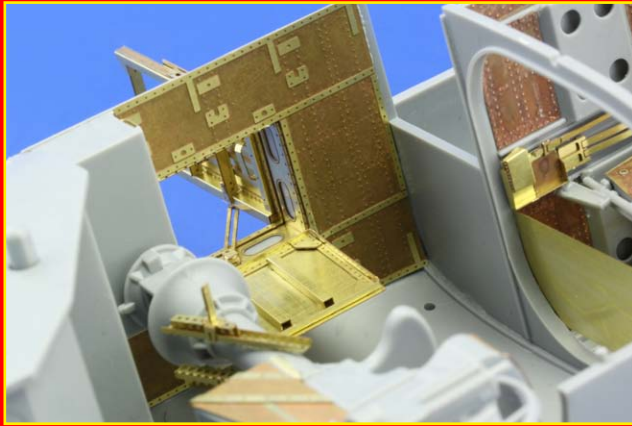

32756 B-25 fuselage interior (BIG3336)



48765 Spitfire Mk.IXc landing flaps (BIG4997)

BIG3336 B-25J STRAFER 1/32 HKM

BIG3337 Ju 88A-4 1/32 REV

BIG4997 SPITFIRE Mk.IXc 1/48 EDUARD

KITS

1186	Good Morning Da Nang	1/48	Limited Edition
7057	MiG-15	1/72	ProfiPACK
4430	Ju 87G DUAL COMBO	1/144	SUPER44

PE-SETS

00027	Circle & oval STEEL		
17528	Figures Regia Marina WWII S.A.	1/350	
32805	F-104G seatbelts	1/32	Italeri
36267	Pz.Kpfw.35(t)	1/35	Academy
48742	Gloster Javelin FAW.9/9R air brakes	1/48	Airfix
48792	F-35B exterior	1/48	Kitty Hawk
48796	Gloster Javelin FAW.9/9R undercarriage	1/48	Airfix
48802	F-4C air brakes	1/48	Academy
48803	Merlin HC.3 exterior	1/48	Airfix
49068	Remove Before Flight FABRIC	1/48	Eduard
49647	Merlin HC.3 interior S.A.	1/48	Airfix
49649	Merlin HC.3 seatbelts	1/48	Airfix
49667	Gloster Javelin FAW.9/9R S.A.	1/48	Airfix
49668	Me 410A-1 S.A.	1/48	Meng
49674	Spitfire MK.IXc late WEEKEND	1/48	Eduard
73495	Harrier GR.3 S.A.	1/72	Airfix

ZOOMS

FE647	Merlin HC.3 interior S.A.	1/48	Airfix
FE667	Gloster Javelin FAW.9/9R interior S.A.	1/48	Airfix
FE668	Me 410A-1 interior S.A.	1/48	Meng
SS495	Harrier GR.3 interior S.A.	1/72	Airfix

MASKS

CX373	F-35A	1/72	Italeri
CX381	F-1 Panther	1/72	Platz
EX416	MiG-25PD/PDS	1/48	Kitty Hawk
EX417	Mirage F.1CT/CR	1/48	Kitty Hawk
EX420	Su-2	1/48	Zvezda
JX163	F-104G/S	1/32	Italeri

BIG ED

BIG3336	B-25J STRAFER	1/32	HK Models
BIG3337	Ju 88A-4	1/32	Revell
BIG4997	SPITFIRE Mk.IXc	1/48	Eduard

BRASSIN

632034	WGr.21 for Bf 109G	1/32	Revell
632036	US 250 lb bombs	1/32	
648137	Mk.82 bomb w/ airbrake late	1/48	
648142	F-4C wheels	1/48	Academy

BUY on Eduard store

Comments and input from J&T

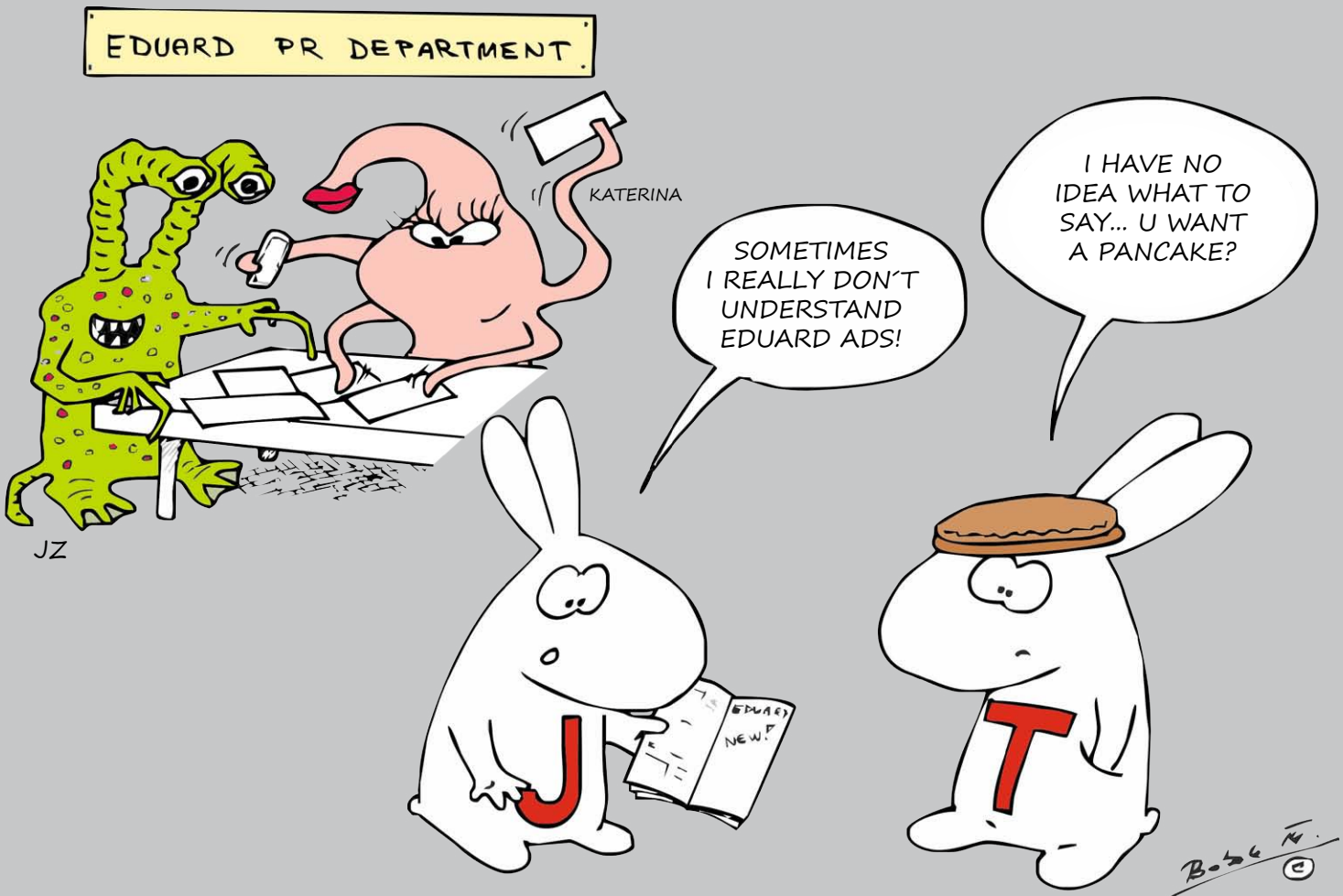

LAST MOMENTS OF GUSTAV AND HIS GUSTAV

**STANO BURSA
PETER KAŠŠÁK**

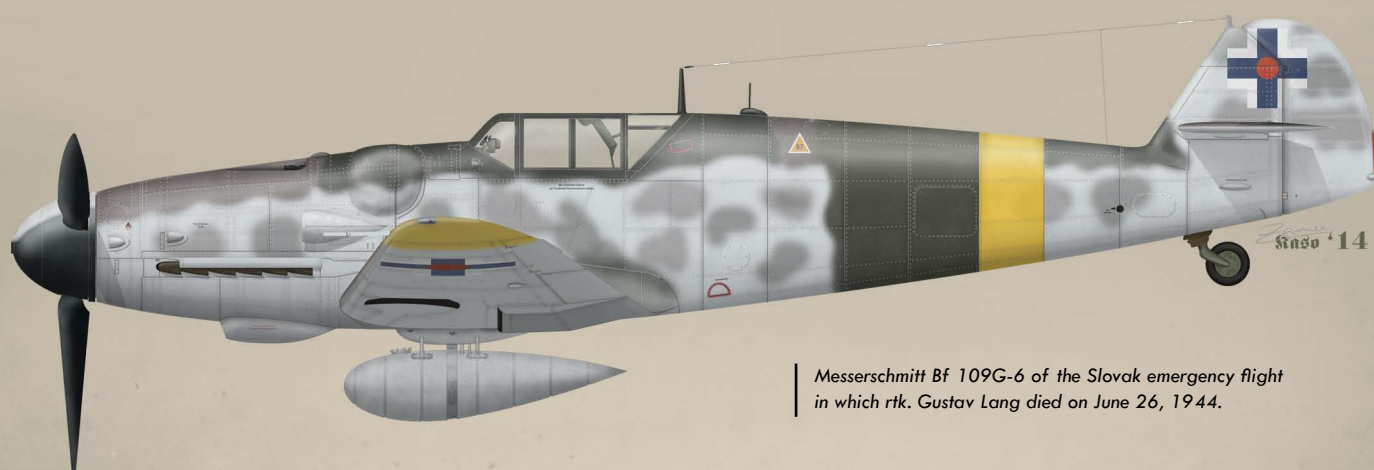

Messerschmitt Bf 109G-6 of the Slovak emergency flight in which rtk. Gustav Lang died on June 26, 1944.

Slovak references that focus on the Second World War in general, and the air war in particular, make significant references to combat that took place on June 26, 1944. The counterparts in the account of what transpired that day include B-24H-10-DT 41-28674 coded '605' and christened 'Citrus Sadie' on one side and a Slovak Messerschmitt Bf 109G on the other. The US aircraft was one of the oldest serving with the 758th Squadron, 459th Bomb Group, and on the noted night was flown by Lt. Lincoln E Artz and his crew, who were not particularly pleased flying such an old airframe, especially when they were required to fly the Tail End Charlie position. This aircraft was attacked and damaged by a Slovak fighter piloted by Rtk. Gustav Lang, flying a Bf 109G-6.

HISTORY

According to some sources, it flew with the radio sign White '10', and its fate and the pilot's life were changed in quick order. The attack ended near the village of Miroslavov. At this point, we would like to present some new facts regarding this event and on the appearance of both aircraft.

American combat boxes flew into Slovak air space almost on a daily basis by 1944, though their targets were not in Slovakia. That is, until June 16, 1944, when Bratislava was bombed. Aerial protection of the Reich (Reichsverteidigung) was the task of Slovak emergency flights composed of Messerschmitt Bf 109Es and Bf 109G-6s which flew from bases in Vanjory and Piestany. On June 26, 1944, the Slovaks entered their first and only combat with the American formations and effectively ceased to exist at that point. Three men died and one was seriously injured. Out of the eight aircraft that took off, six failed to return. This was a high cost for the B-17 damaged reported by ctk. Rudolf Bozik. According to all available references, Rtk. Gustav Lang attacked a B-24, but the question must then be raised, did he attack and damage it to the point where it crashed? Based on the latest research, it is highly probable that the victory was claimed post mortem by colleagues and officials based on the close proximity of the pilot's death and the landing site of the American bomber crew. So, what really happened and what do the facts tell us?

On the morning of June 26, 1944, none of the players of the pending combat believed that this should somehow prove to be a fateful day. And fate had other ideas for them, crossing their paths when under different circumstances, they all might've been



The engine of Lang's aircraft after the crash in a hay field near the village of Miroslavov. (L. Zdravil via F. Stellar)

very good friends, but now they came together as enemies.

Gustav Lang's fiancé, F. Simkova (born Sedlakova) was the last of his family to see him alive. He was at her home on an unauthorized leave of absence to discuss the wedding. When Gustav arrived at Piestany in the morning, his comrades were already mounted in their planes, ready to take off. He ran across the field to the waiting planes, jumped on the wing of one occupied by ctk. Rudolf Palaticky and told him 'Let me in, I'm supposed to fly this one....otherwise, I'm in deep!'

So, they swapped G-6 cockpits and Lang took with him only his parachute and helmet, and in a few seconds, eight aircraft

took off from the airfield. Takeoff occurred at 0840h, and Gustav Lang served as leader of the third pair only in his summer uniform and summer shoes. There was no time to put on a flightsuit.

...DESCRIBES THE LAST MOMENTS OF THE B-24 OF LT. ARTZ AND OF THE FATE OF THE MESSERSCHMITT BF 109

The following report was filed at the Most na Ostrove police station and describes the last moments of the B-24 of Lt. Artz and of the fate of the Messerschmitt Bf 109:

'I report that on June 26, 1944, at 1000h approximately 1,000 US Liberator aircraft flew from the southeast and circled in the area of Male Karpaty - Velky Zitny Ostrov accompanied by Lightning fighter aircraft. Over the village of Most na Ostrove, district of Bratislava, Slovak and German pilots

The first of the new information to come out was already mentioned in Moulton's book of memoirs. It includes the name of the plane, 'Citrus Sadie'. We were able to source photos of the noseart of this veteran B-24 with different crew posing in front of it. Based on known information, we reproduced the likely look of the bomber. The 459th BG began using a fuse-

lage code composed of a number, which corresponded to one of four squadrons, and the number of the plane which identified the aircraft and was assigned at Giuliana Air Field. Our B-24 41-28674, wears the code 8K. However, there is no evidence to suggest that any of the old Olive Drab camouflaged planes wore this code prior to August, 1944.

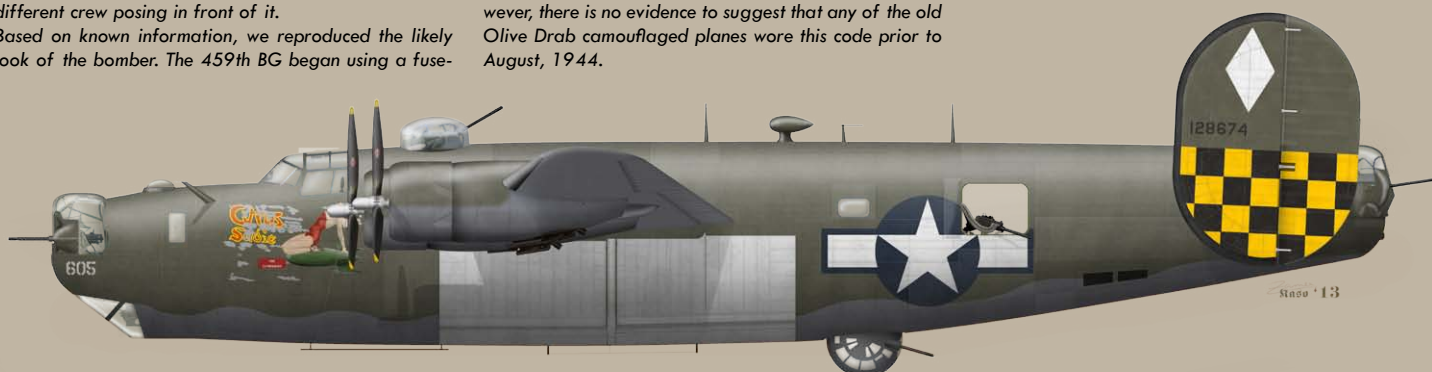



Rear part of the fuselage of the Bf 109. Clearly visible is the absence of the White '10'. (L. Zdrzil via F. Stellar, R. Tupy)

attacked the enemy in their Messerschmitt aircraft. They attacked at an altitude of 6,000m. Among them was rtk. Lang, who attacked one American bomber that was lagging behind and shot it down.

'Suddenly, two American twin tailed fighters appeared to protect the US bomber and attacked

rtk. Lang and shot him down. The US bomber crashed in Hungary, south of Kolinkovo. Eight crew members took to their parachutes and landed on the Slovak-Hungarian border near the villages of Studene (Hidegket) and Miroslavnov. The landing zone was immediately secured by the local police station and its members captured four of the crew members. These were sent to the National Ministry of Defense in Bratislava. Three of the enemy airmen were captured by Hungarian soldiers. One airman had not yet been captured.'

This police report agrees with US archive materials on the fact that Artz's Liberator was hit at an altitude of 6,500m, but its claim of Lang being hit by the Lightnings cannot be substantiated. The description of the final moments of Gustav Lang's flight were reported by police who could not have made out what was going on 6,500m above their heads. They only knew that the P-38s chased Lang near ground level just prior to his crash.

Another version of events was described by Lang's wingman, rtk. Karol Geletko:

'.....Puskar ordered the release of drop tanks, and five or six of our boys had already done so when we were bounced by Mustangs from

above. Possibly twenty to twenty-five of these attacked. At that point, our formation broke apart. Stauder was hit, Ocvirk was spiraling to the ground and so was Jambor. What happened to them later, I do not know. There

...IF THAT DOESN'T HELP, PULL OUT OF THE SPIN AND FLY HOME OR BAIL OUT!

was no time to look around... it was a merry-go-round. I heard Stevo Ocvirk pleading for advice: 'Lord, boys, I am in a spin, what do I do??' Despite having

his own problems, Lang replied 'shit your pants, and if that doesn't help, pull out of the spin and fly home or bail out!' Lang and myself were attacked by one flight. We tried to escape in a controlled spin, but it did not help. Suddenly, I heard Stauder on the radio 'Guys, my engine's on fire but these are cavaliers, they escorted me to the ground. He landed somewhere in a hay field. Meanwhile, I heard Ocvirk who managed to pull out of his spin. Up above, Lang and I remained alone. Suddenly, artillery hit one of the American bombers, and airmen bailed out of the crippled aircraft. At the same time, two Mustangs left the formation and started towards us. I informed Lang: 'look - they have us in their sights.' Lang replied 'Do you think they might hit us?' at which point he was hit. I saw it close up, as he was only a few meters away from me....directly into his face. He lost control over his Messerschmitt and we nearly collided. I started to descend rapidly....'

American bullets hit the Slovak Bf 109G-6. One 12.7mm shell exploded in the cockpit and a fragment hit him in the forehead. In shock, he rolled over towards the ground. Certainly near death, his instincts told him to try to belly land a few meters above the ground. This occurred over the village of Stvrtok na Ostrove.



The impact site near Miroslavov. (R.Tupy)



The remains of the cabin and the landing gear. The seat was thrown clear on impact, and his body was almost intact. With observation of the wreckage, it is difficult to imagine the severity of the impact. (L. Zdravil via F. Stellar)

Further events were described by eyewitnesses. J. Sinna: 'Near Stvrtok was a lone Messerschmitt, when it was bounced by two twin engined enemy fighters. At that time, airmen began to bail out of a burning US bomber over Studene. From what I saw, seven of them jumped. I was in the field, preparing to harvest. The twin engined fighters followed the Messerschmitt, flying just 10m above the ground. They kept firing at it. The Messerschmitt was all full of holes, with oil and fuel leaking and streaking from the aircraft, and where it hit the ground, it burned a bit. It settled down near Miloslavov close to the cemetery. We had a corn field nearby, and I was worried, but it did not cause a lot of damage. Damage was limited to a 50 by 50m area. The engine remained on the Slovak side of the border and the remainder of the fuselage was on the Hungarian side. Half of the American crew was captured by Hungarians, and the other by Slovaks. The bomber flew towards Kalinkovo and according to some witnesses crashed in the Danube.

Citizen of Miroslavov, Jan Spevak, recalled: 'The damaged plane flew from Bratislava towards Samorin. One side of it was in flames. It flew at a high altitude, and I was looking at it with binoculars. I could see black dots emanating from the aircraft, and these resulted in parachutes. I recognized these as airmen bailing out of the stricken aircraft.'

Near our village of Miroslavov, there was anti-aircraft battery that kept firing on the enemy aircraft. Their sounds were mixed with those of the aircraft guns. I spotted three aircraft flying from the direction of Cakan just above the ground. Kust across the border, one of the crashed in a cloud of dust and smoke. The plane rolled for about 300m, and it disintegrated about 40m short of the border. Its engine continued on into Hungary, where it was finally stopped by a group of small trees about 80m inside the border. It all happened so quickly, and it was hard to know what to watch first. Pilots of the twin engined aircraft had their hands full just trying not to hit the ground as well. One managed to do it just over our garden, and one more about 300m away. At full speed, they pulled up and left.

Out of the burning bomber, three men landed on our ground and immediately hid themselves. A fourth landed about a kilometer further inside Slovak territory. I ran to the crash site and was among the first people to

arrive. The aircraft was wrecked, and the pilot was in the seat, although the seat was not in the aircraft. He was still alive, but in lethal shock. We unfastened him, and released him of his parachute. He was all covered in dust and his face was obscured. Both legs and one

**I RAN TO THE CRASH SITE
AND WAS AMONG THE FIRST PEOPLE
TO ARRIVE. THE AIRCRAFT WAS WRECKED.**

hand were broken. We carried him from the Hungarian side of the border to the Slovak side and later, he was taken to the mortuary.'

,The pilot only had walking shoes on his feet. He wore simple trousers, and his shirt had the sleeves rolled up. They told us he was a German, but the trousers were Slovak. We did not understand why he was dressed the way he was, but we assumed that he had taken off in a hurry. He had only his parachute, which we used as a cover at the mortuary. He did not even appear to have a proper flight helmet.'

The killed Slovak airman was rtk. Gustav Lang, and he was buried together with his colleagues napor. Juraj Puskar and rtk. Stefan Jambor at Piestany on June 29, 1944 and one day later, he had a civilian burial at Marianka.

Slovak air war history enthusiast Juraj Rajnec published long ago the information that Lang, on June 26, 1944, flew Bf 109G-6 W. Nr. 161713 with the fuselage code White '10'. Based on this information, Stanislav Bursa and J. Andal reconstructed the look of the airplane for HT magazine on Page 35. Today, however, it is necessary to add that the aircraft did not carry the number '10'. From photos taken at the crash site, it is obvious that no number was carried. Also, the W.Nr cannot be determined with certainty. Out of the two, it is not clear which aircraft was flown by Lang and which was flown by Jambor. There are two candidates: W.Nr. 161713 and 161723. Both pilots fell victim to Mustangs of the 31stFG who claimed Bf 109s shot down in the area of Bratislava between 0915h and 0945h.

To this day, it is also not certain where B-24H-10-DT, 41-28674 of Lt. Artz crashed. Unconfirmed sources say he crashed near Samorin. However, Lehnice are also mentioned, which is 20km to the east. No one seems to know anything about a crashed bomber at



A photo of the official burial ceremony of G. Lang. The coffin was carried on the fuselage of a training plane. (L.Zradil via F. Stellar)



The gravestone of Gustav Lang in his birth village of Marianka taken in 2002.



An unknown 459th BG crew pose in front of 'Citrus Sadie'.



The wrecked US bomber near maly Biel. It is highly likely that it was Artz's plane. (Via F. Stellar)



The four US airmen from Lt. Artz's crew pose with Slovak soldiers a few moments after their capture. (L. Zradil via F Stellar)

either site. It is possible that the research of Fredinand Stellar is correct. He located photos showing an Olive Drab painted US bomber crashed in a field close to Maly Biel near Senac. It is possible that the plane, set on auto pilot, crashed there.



eduard
BRASSIN

eduard

ACCESSORIES FOR:

Bf 109G-6

1/32 Revell

632025

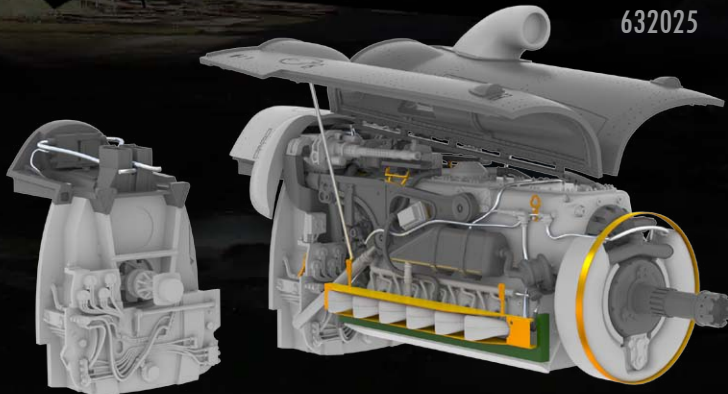

BRASSIN ACCESSORIES

- 632025 Bf 109G-6 engine
- 632022 Bf 109G-6 cockpit
- 632021 Bf 109G-6 undercarriage legs BRONZE
- 632020 Bf 109G-6 exhaust stacks
- 632018 Bf 109G-6 wheels
- 632035 Bf 109G cannon pods
- 632034 WGr.21 for Bf 109G



632021



632022

PHOTO-ETCHED SETS

- 33128 Bf 109G-6 interior S.A.
- 32788 Bf 109G-6

632020

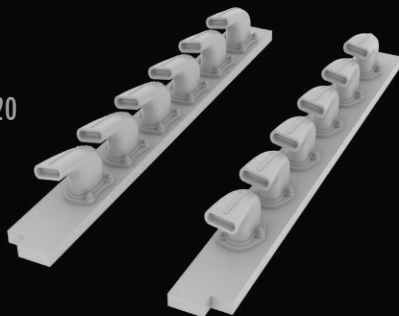

632018

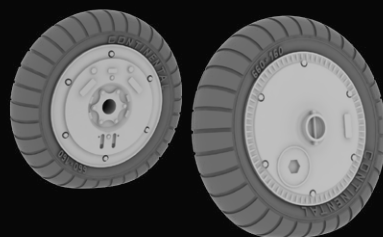

PAINTING MASK

- JX151 Bf 109G-6

632035

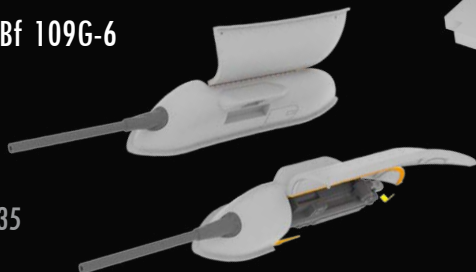

632034

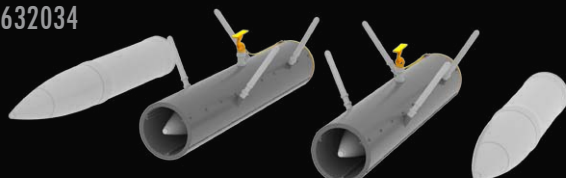

33128

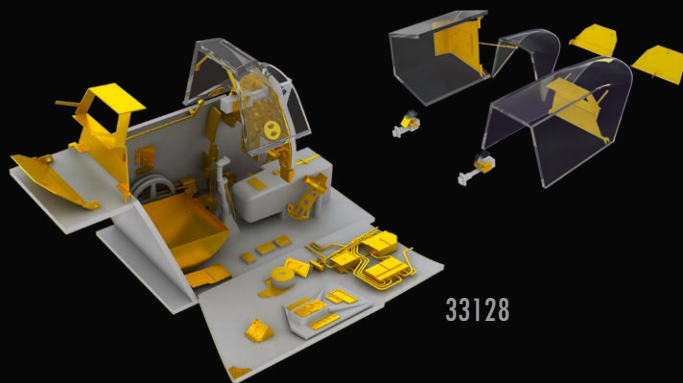

32788

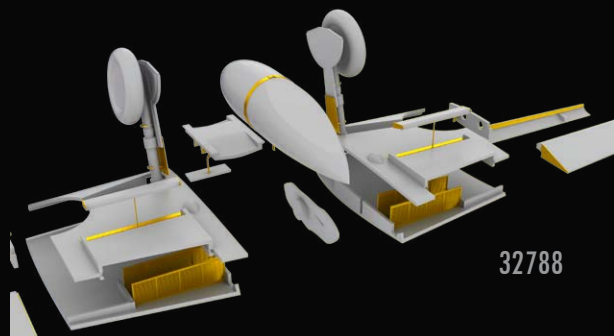

GOOD MORNING DA NANG!

Cat. No. 1186, 1/48

BuNo. 151492, VF-84 „Jolly Rogers“,
USS Independence, 1965



built by Petr Zatrepálek

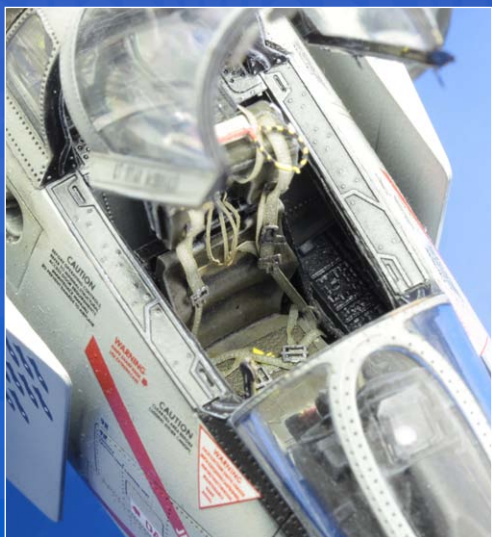



BUY Good morning Da Nang 1/48

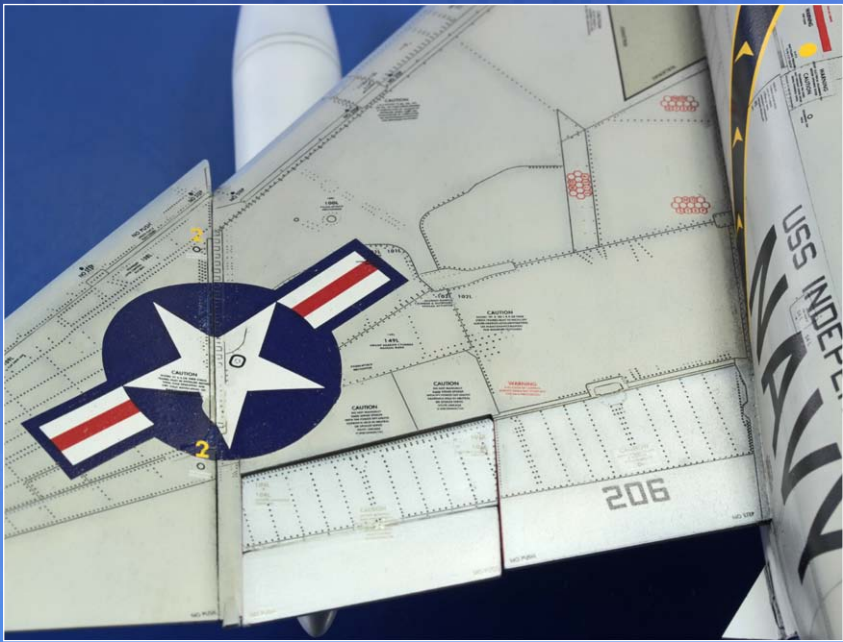

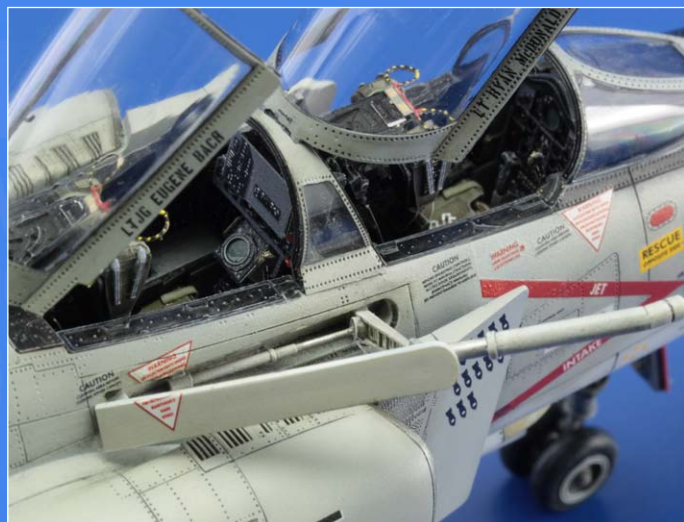
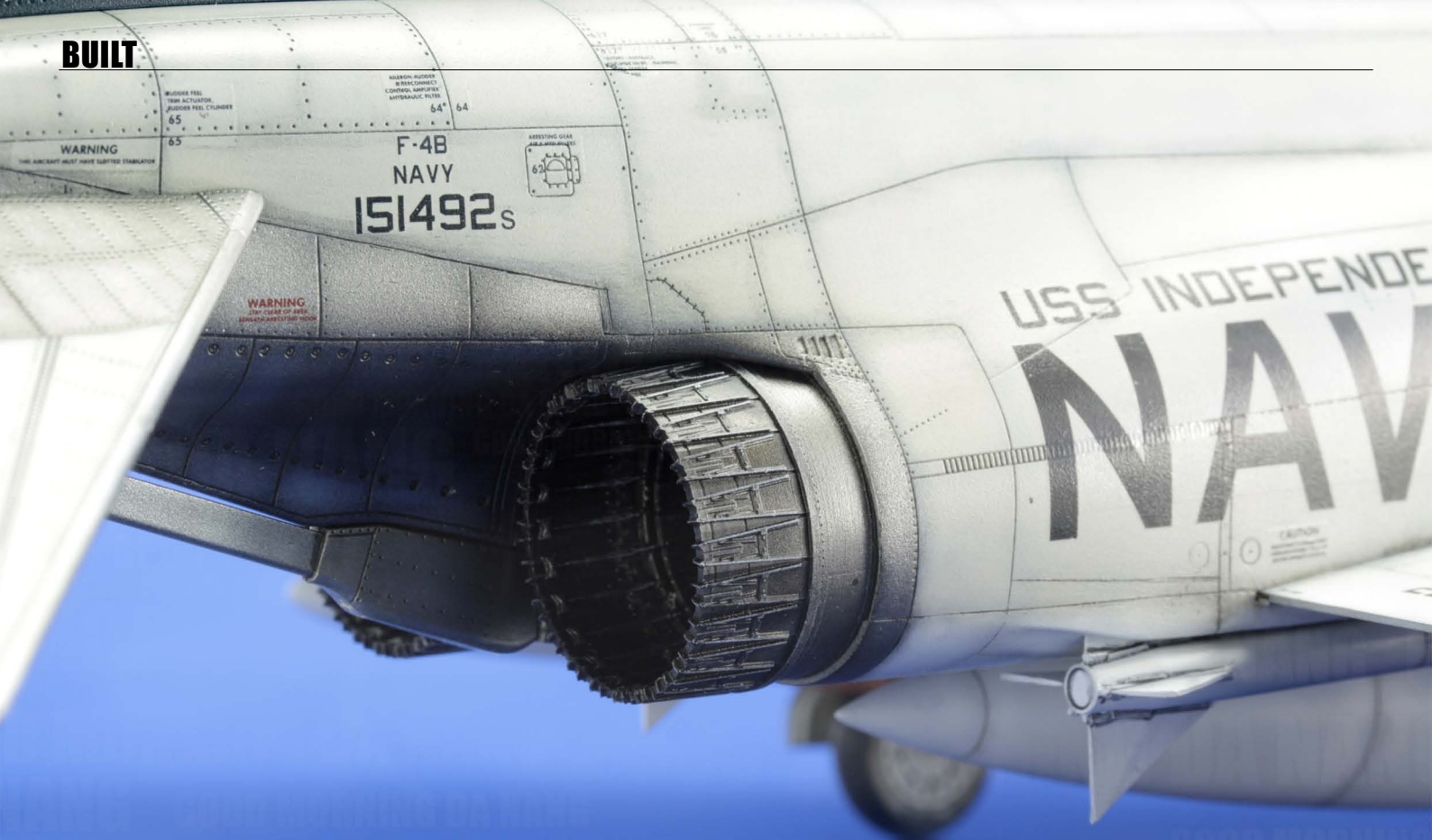



T-28B

1/48 Roden

USED PHOTO-ETCHED SETS:

- FE601 T-28 S. A.
- 49601 T-28 S. A.
- 48740 T-28 povrchové panely S. A.
- 49009 Remove before flight 1/48

PAINTING MASK:

- EX355 T-28B



BUY PE-SETS T-28 1/48

built by Matthias Bittner, Jet&Prop magazine



náhled fotoleptů



PE-SETS test application - built by Jiri Broz.

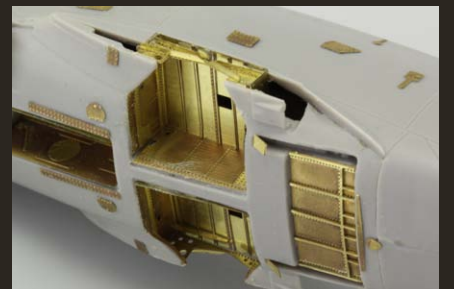

MOTOR

Bf 109G-6

1/32 Revell

- Detailed DB 605 engine for Bf 109G-6, with all external accessories (except the bottom part details) plus propeller reducer and engine bearer.
- Complete engine
- MG 131 machine guns section, plus guns accessories
- Complete engine housing

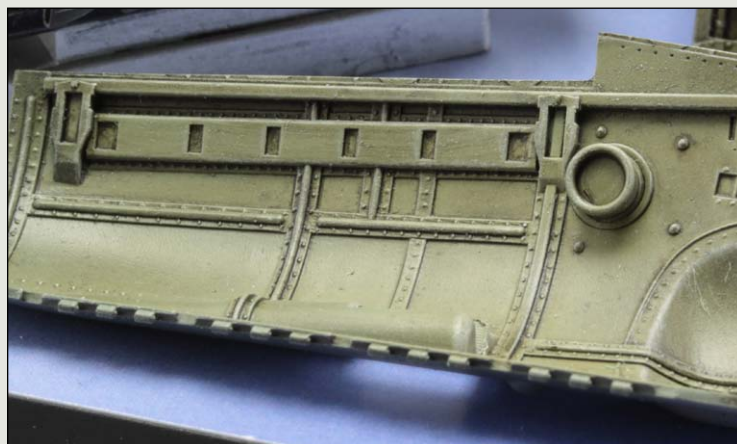
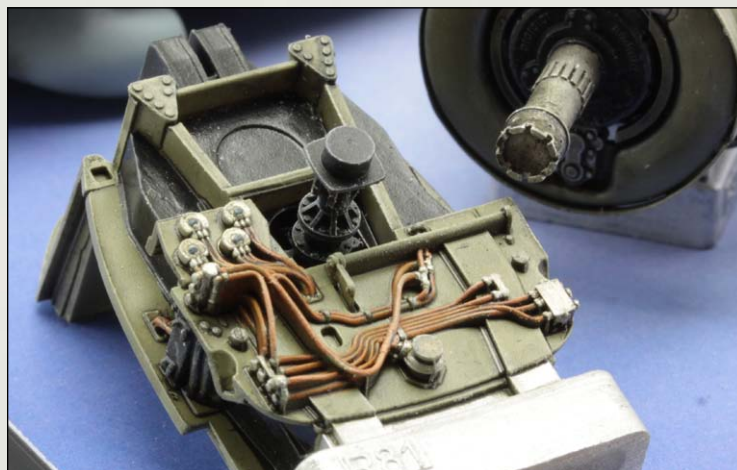
BUY
eduard
BRASSIN
built by Petr Zatléřpálek

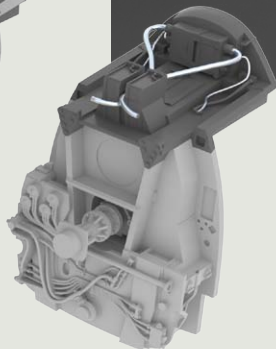
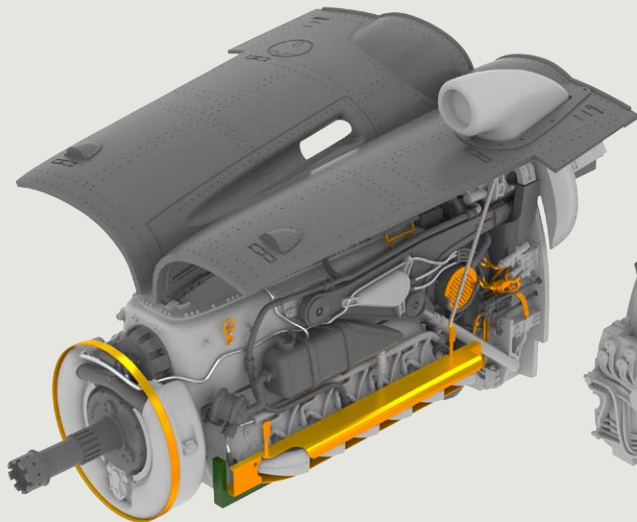
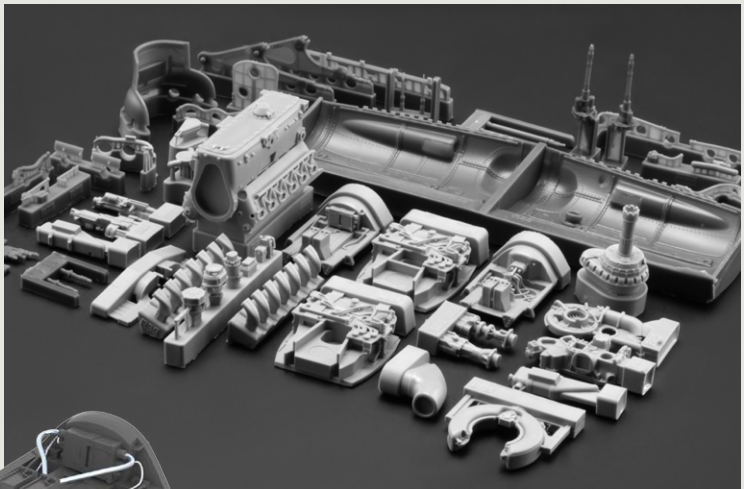
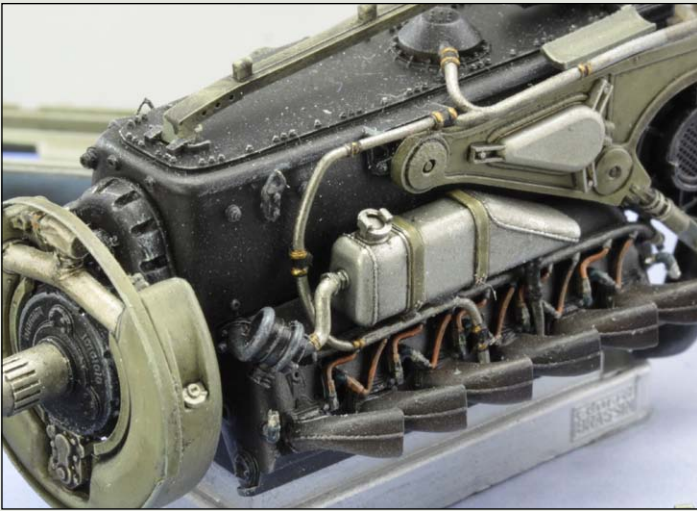
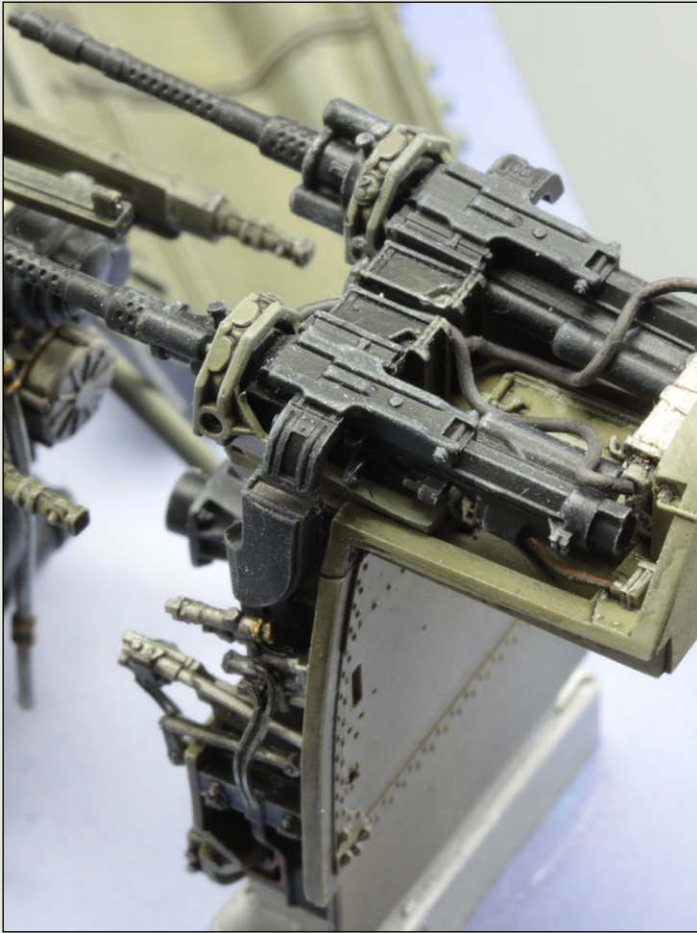

photo:
Jan Zdiarský
Kateřina Borecká
Jan Bobek

spielwarenmesse®

Nürnberg 29. Jan - 3. Feb 2014



Second showcase represents our philosophy of complete solution.



Mafia Boss



Petra Pavličková (sales department).

Vladimír Šulc
and Václav Bílek

eduard



Mr. Sulc with Mr. Ono – a long time cooperator and a legend of Japanese plastic kit and toys market.



Jason Lake from the LSA (one of our UK distributors) with Petra Pavlickova and Martin Finger (Eduard business department).



Dragon



Artesania Latina



Look inside – Petra Šolcova on the front desk in discussion with Karel Padar.



business



The second Award was for our photo-etch for the M-ATV MRAP 1/35 by Kinetic.



Roden



Jason Lake and Petra Šolcova

Liquere?
Not, this is a brand new sample of a new Gunze line.



„Mmm, smells good“ (Karel Pádár)



„Cheers!“



An excellent relationship of manufacturer and distributor (Mr. Sulc with Jason Lake of the LSA (UK)).



A unique „guest“ on our stand - our friend Jan Bobek... for those who does not know father of the E-BUNNY.



The middle shelf of the third showcase is full of B-17G in 1/32 (HKM)... shows our approach in tuning interesting models of other kit producers – covered by our Brassin, masks and photo-etch lines.



Atmosphere from the competition.



PUZZLE 33600 pcs

JanZ in left with Gary Hatcher of the SAMI. Martin Ferkl and Vladimír Sulc.

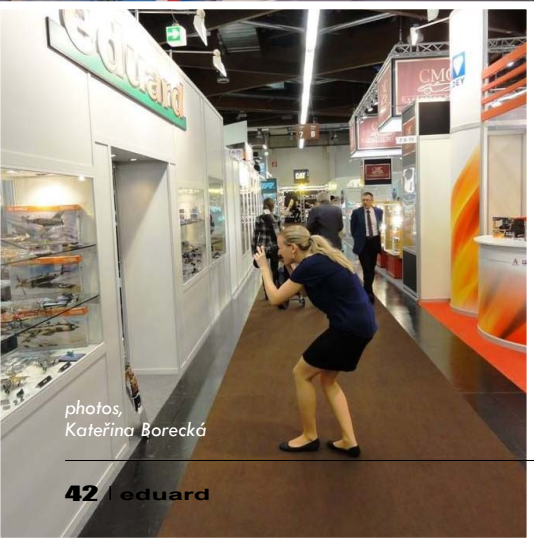

photos, Kateřina Borecká

ON APPROACH

BIG ED (April)

- BIG5320 IJN Chikuma 1/350 Tamiya
- BIG3338 Me 163B 1/32 Meng
- BIG4998 B-29 1/48 Monogram/Revell
- BIG4999 MiG-23MF 1/48 Trumpeter

BRASSIN (April)

632032
F4U-1 engine
1/32 Tamiya

632033
B-17 superchargers
1/32 HK Models

632035
Bf 109G cannon pods
1/32 Revell

648133
Spitfire 30gal slipper tank
1/48 Eduard

672033
British WW2 bombs
1/72

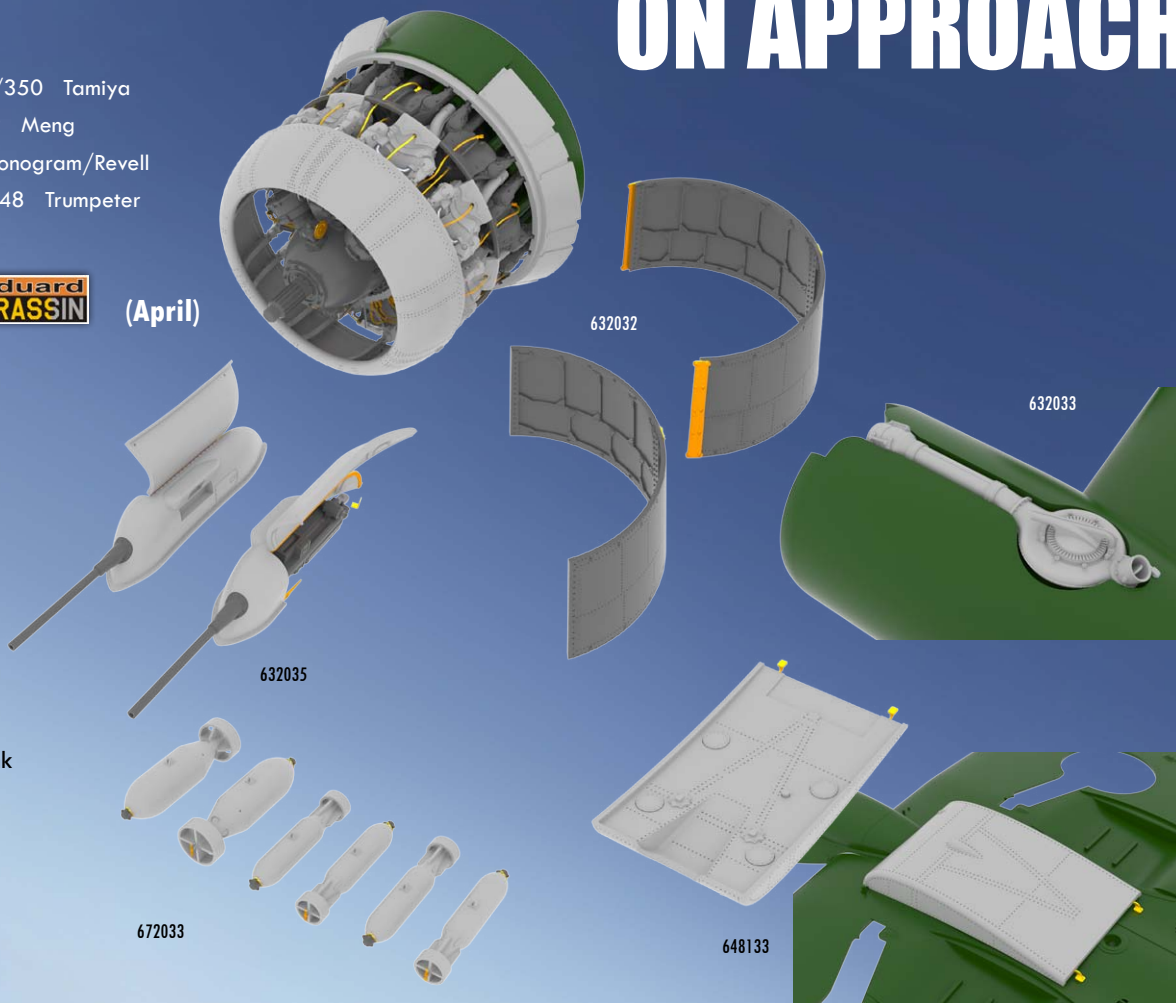

KITS

(April)

2115
Bf 110C-6
1/72 Limited edition

84137
Spitfire IXc
early version
1/48 Weekend

8066
P-39L/N
1/48 ProfiPACK

PHOTO-ETCHED SETS (April)

PE-SETS

00026	Kapátko	tool	
00028	Template oblongs & square STEEL	tool	
00029	Template oblongs STEEL	tool	
17527	Figures Regia Marina WWII 1/700	1/700	
32808	F-104 C2 seatbelts	1/32	Italeri
32803	F-104G interior S.A.	1/32	Italeri
32806	N1K2-J Shiden Kai S.A.	1/32	Hasegawa
32807	Remove Before Flight FABRIC	1/32	
32811	F-104 undercarriage	1/32	Italeri
36263	ATF Dingo 2 GE A PatSi interior	1/35	Revell
36264	ATF Dingo 2 GE A PatSi exterior	1/35	Revell
48764	A3D-2 bomb bay	1/48	Trumpeter
48791	A3D-2 undercarriage	1/48	Trumpeter
48801	L-29 Delfin exterior	1/48	AMK
48804	Mirage F.1CT/CR exterior	1/48	Kitty Hawk

49665	A3D-2 interior S.A.	1/48	Trumpeter
49675	Mirage F.1CT/CR interior S.A.	1/48	Kitty Hawk
49676	L-29 Delfin interior S.A.	1/48	AMK
49677	A3D-2 seatbelts	1/48	Trumpeter
53099	USS Arizona part 1-cranes 1/200	1/200	Trumpeter
53100	USS Arizona part 2-catapults 1/200	1/200	Trumpeter
53104	USS Arizona part 3-life boats 1/200	1/200	Trumpeter
73496	Harrier GR.1 S.A.	1/72	Airfix
73497	F-35A S.A.	1/72	Italeri

ZOOMS

33131	F-104G interior S.A. 1/32	1/32	Italeri
33132	N1K2-J Shiden Kai interior S.A. 1/32	1/32	Hasegawa
FE665	A3D-2 interior S.A.	1/48	Trumpeter
FE675	Mirage F.1CT/CR interior S.A.	1/48	Kitty Hawk
FE676	L-29 Delfin interior S.A.	1/48	AMK
SS496	Harrier GR.interior 1 S.A.	1/72	Airfix
SS497	F-35A interior S.A.	1/72	Italeri



36263
ATF Dingo 2 GE A PatSi
1/35 Revell

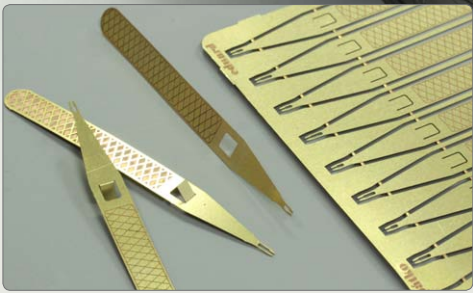

00026 Kapátko



32806 N1K2-J Shiden Kai S.A.
1/32 Hasegawa

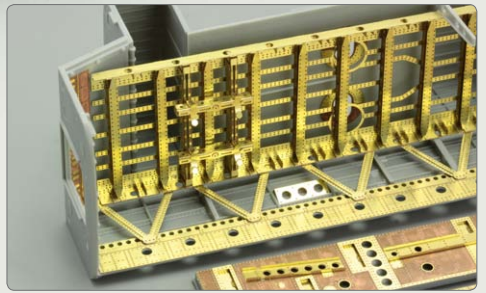

48764 A3D-2 bomb bay
1/48 Trumpeter



48801 L-29 Delfin exterior
1/48 AMK

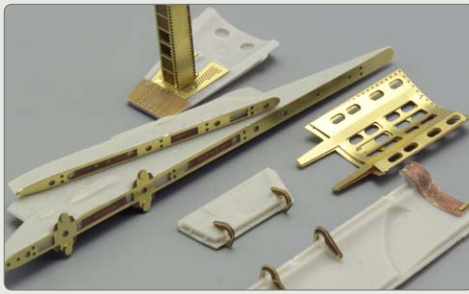

48804 Mirage F.1CT/CR exterior
1/48 Kitty Hawk



53104 USS Arizona part 3-life boats
1/200 Trumpeter

PREORDERS FOR MOSON SHOW 2014

14.3.2014 – 31.3.2014 at Eduard Store
15% discount, 20% discount for BFC members

To apply your discount, choose „MOSON personally (HU)“ or „MOSON BFC personally (HU)“ as the delivery method of your order, in the 3rd step of the shopping cart.

Your discount will be applied after choosing this delivery method.

Preorders **can be payed using credit card** only or **by cash** at the stand on the Moson show. You can pay in CZK, EUR and HUF currencies (applies only for cash payment at the stand).

Gunze products cannot be preordered at Eduard Store by foreign customers, but they will be available at Eduard's stand on the Moson show.