

Fuselage

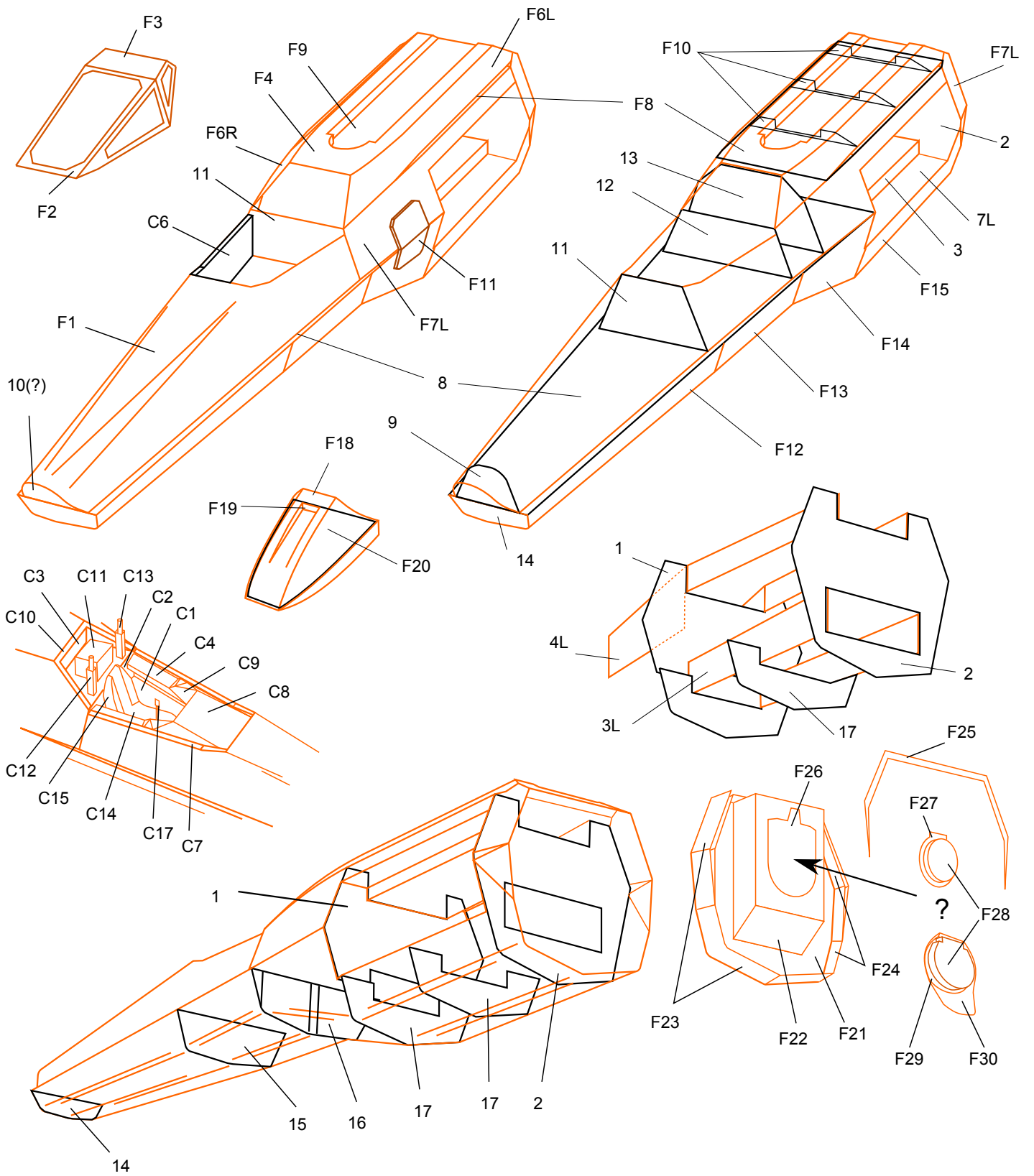

Wing

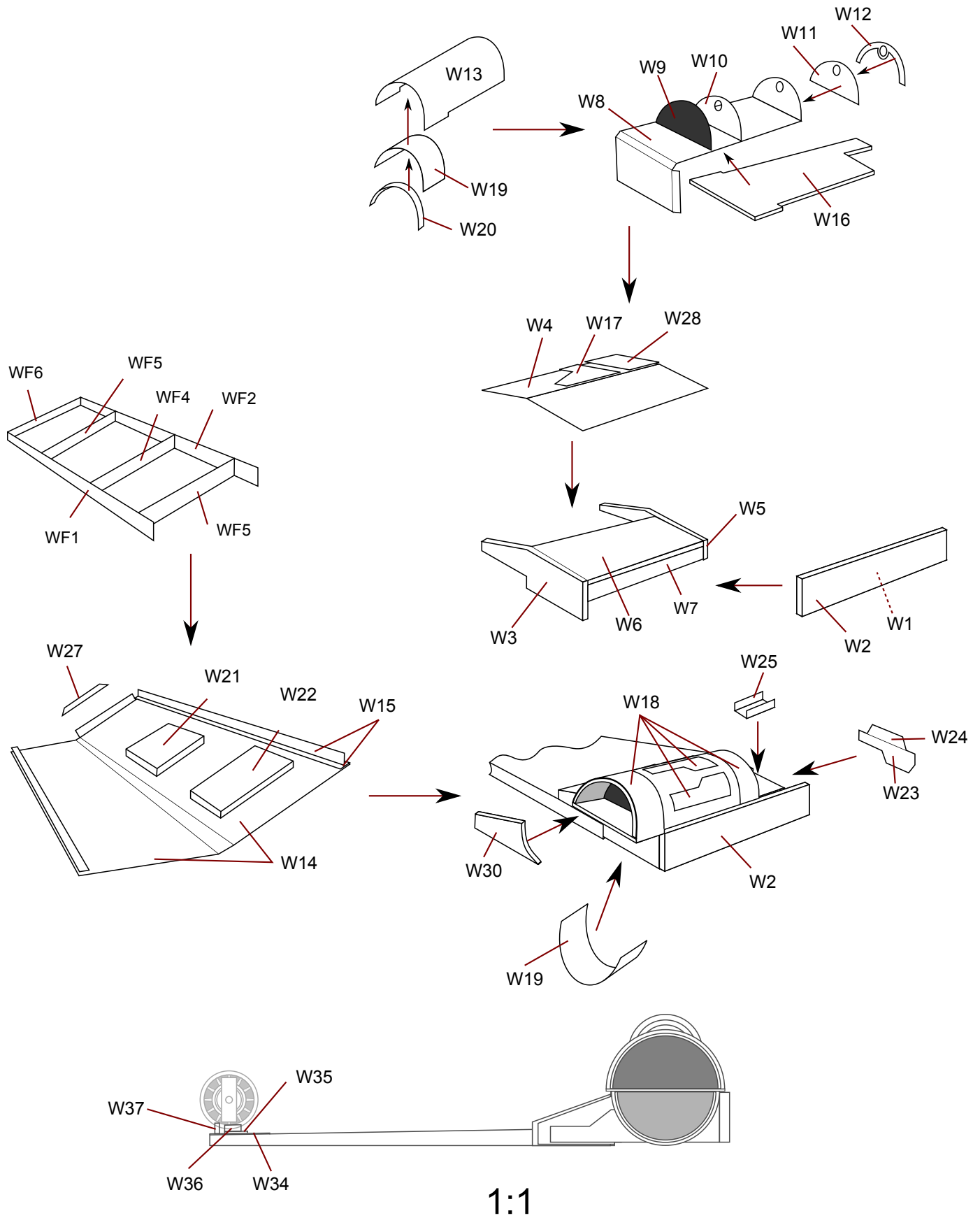

Droidplate

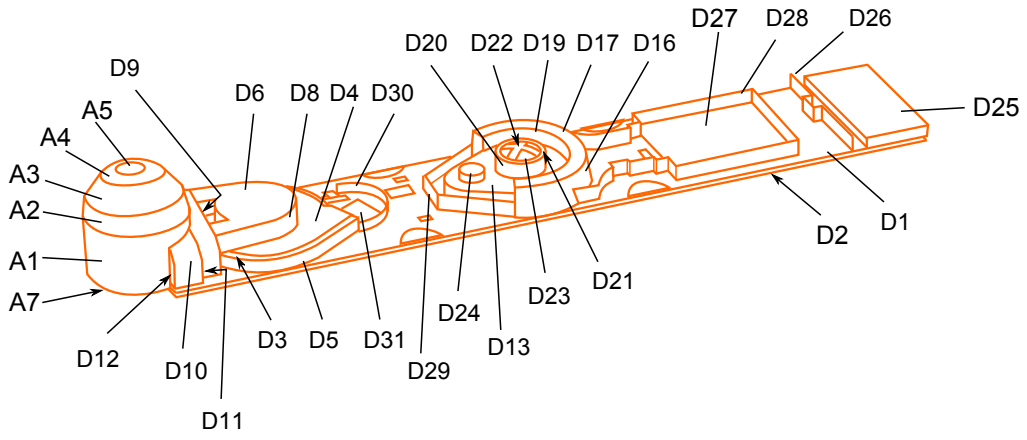

Wing inlet

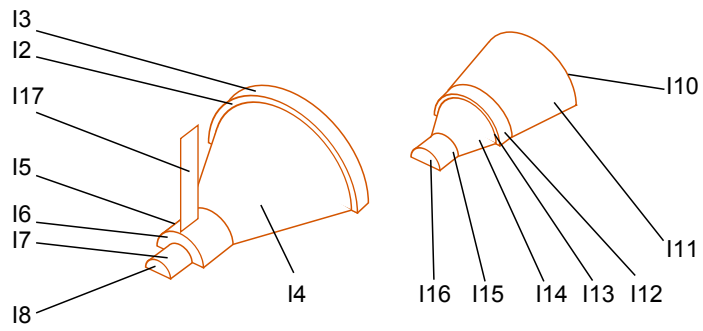

Engine

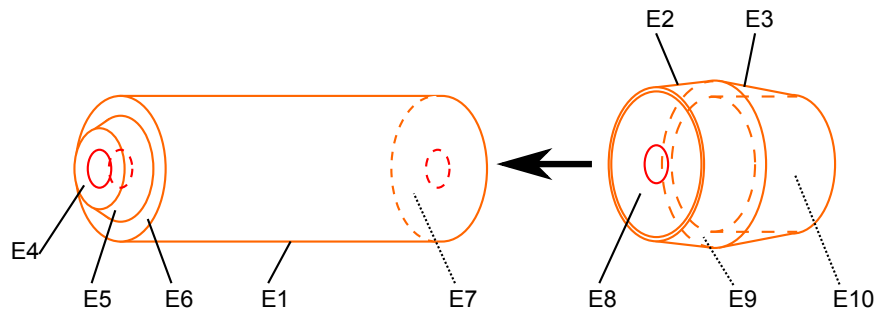

Cannon

Recommended paper thickness:

~0,15 mm (80-100 gsm) if not specified otherwise

~0,25 mm for parts 6, 6a, 7, 13, 15b 16, 20

~0,5 mm for parts 14, 6b

~1 mm for part 6c

part A: use a round piece of wood (plastic, etc.) - diameter 2mm, length 120mm

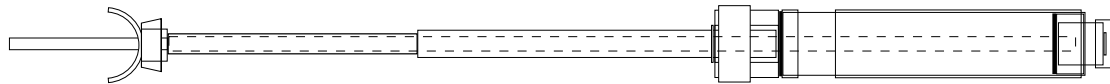
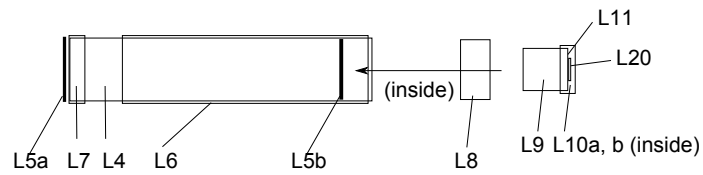
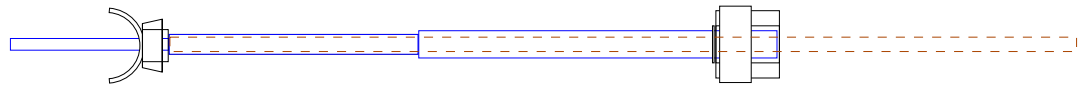
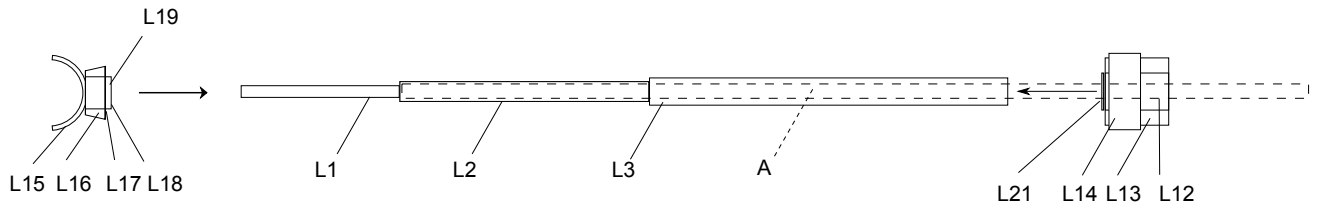

1:1

Fuselage assembly tips

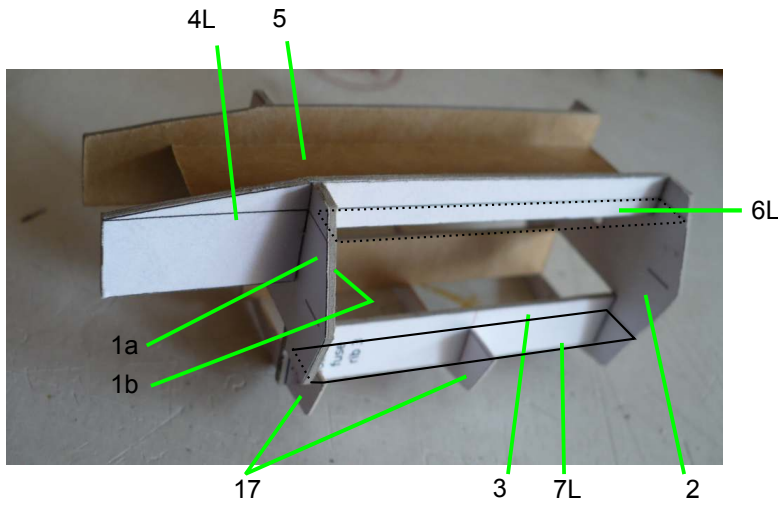

glue the torpedo tubes from the inside start the bottom cladding with this section



dry-fit the skin by wrapping it around the ribs from side to side. If there's some space left between the rib and the cladding, attach small strips of paper to fill it

attach the skin to the fuselage base frame on one of the sides, then glue it to the ribs and finish on the other side

don't glue together yet, it'll help fitting the aft section easily

glue the aft section to the lower fuselage part, then join the upper and lower fuselage (red lines). Attach the aft cap to finish this section.

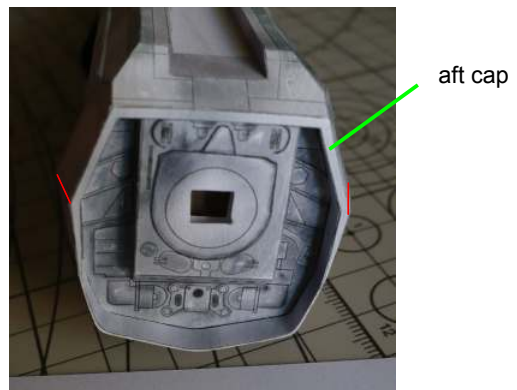
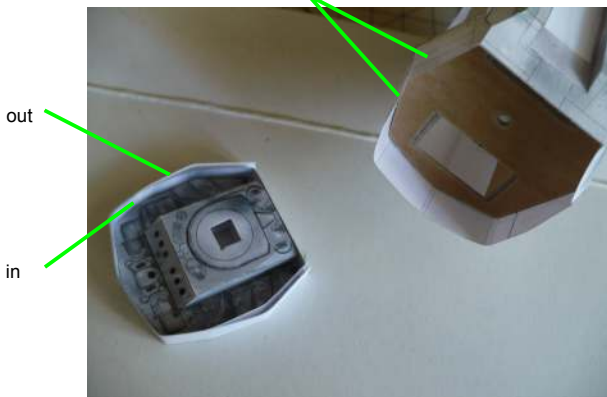

Assembly tips

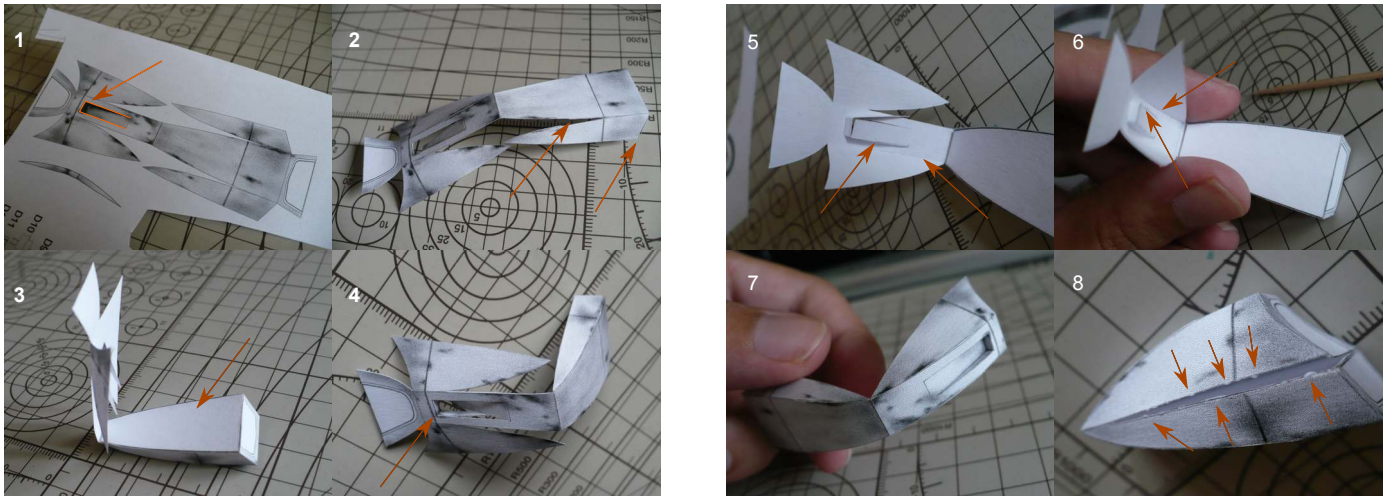

1. cut the notch base sides first, continue with the rest of the edges
2. glue the lower backside of the lower half, continue with its sides
3. add the thick base (F20) to form the final shape and strengthen the nose
4. continue with gluing the backside of the notch (F19) to the main nose part
5. glue one side of the upper half of the nose first, then one side of the notch
6. glue the center of the notch and continue with the second side
7. finalize the nose's upper part by gluing its backside
8. apply small drops of glue to the edges of the upper and bottom half, press them against each other gently and move your finger along the edge